

Poinsett's Cavalry Tactics for Reenactors



By
Michael J. Riggleman

A publication of the
2nd US Cavalry Co. A / 9th VA Cavalry Co. D
Training Committee

Copyright © 1999, 2005, 2012
Michael J. Riggleman

All rights reserved. No part of this publication may be reproduced, stored in a retrieval system or transmitted in any form or by any means, electrical, mechanical or otherwise without the written permission of the author.

Printed in the United States of America with the permission of the author.

Figures of all drill maneuvers are computer generated by the author.
Original sketches are thanks to the talents of Jim Hatzell, Rapid City, SD.

My special thanks to two modern-day warriors, Lt Col David Mize, USAF and
SFC Steve Davis, USA for their editing suggestions and many hours of proof reading.

19 February 2012

To whom it may concern,

I Michael J. Riggleman, the author of the booklet titled *Poinsett's Cavalry Tactics for Reenactors*, grant anyone permission to reproduce my booklet. Permission is granted to make unlimited hard copies or to distribute the electronic version by any means (including email, or posting to a web site for download).

There are only three restrictions to my granting permission:

- 1) No profit may be made from the sale of my booklet. It is permissible to charge enough to recover reproduction costs, as long as no net profit is made from the sale of the book. This restriction does not apply to professional printers, who may charge their normal fees for reproduction.
- 2) All copies must clearly show myself as the original author, and due credit given to the Training Committee of the 2nd US Cavalry Co. A / 9th VA Cavalry Co. D reenactment group for the text and drill diagrams of the booklet, and to artist Jim Hatzell of Rapid City, SD for the original sketches of the trooper in the manual of arms section, and for the portrait of the author on the back cover.
- 3) No changes may be made to any of the text, diagrams, or artwork. If anyone sees an error, please contact me at the email address below and I will make all changes and corrections and forward them a new modified version of my booklet.

Take care, and ride safe,



Michael J. Riggleman
mike_riggleman@hotmail.com

TABLE OF CONTENTS

	PAGE
Introduction.....	1
General Principles.....	1
Terms & Definitions.....	3
 <u>DRILL COMMANDS</u>	
1. Falling In.....	4
2. Counting Fours.....	4
3. Mounting.....	4
4. Dismounting.....	5
5. File Off.....	5
6. Dressing the Formation.....	5
7. Opening Ranks.....	5
8. Closing Ranks.....	6
9. Break Platoon by File.....	6
10. Break Platoon by Twos (or Fours).....	7
11. Commence the March At a Walk.....	8
12. Commence the March At a Trot.....	8
13. Halting the Column.....	8
14. Turning the Column.....	9
15. Obliques.....	10
 <u>LINE FORMATIONS</u>	
16. Front Into Line.....	11
18. Left Into Line.....	13
20. On Right Into Line.....	15
22. Moving from Two Ranks to a Single Rank.....	17
23. Moving from a Line in a Single Rank to Double Ranks.....	18
 <u>CHANGING THE BREADTH OF THE COLUMN</u>	
<u>AT THE SAME GAIT</u>	
24. Column of Twos from a Column of Files.....	19
25. Column of Fours from a Column of Twos.....	20
26. Increasing the Breadth of the Column at the Same Gait.....	20
27. By Twos from a Column of Fours.....	21
28. By File from a Column of Twos.....	22
29. Reducing the Breadth of the Column at the Same Gait.....	23
 <u>DOUBLING THE GAIT</u>	
30. Column of Twos from a Column of Files.....	23
31. Column of Fours from a Column of Twos.....	23
32. Increasing the Breadth of the Column in Doubling the Gait from the Trot.....	24
33. By Twos from a Column of Fours.....	24
34. By File from a Column of Twos.....	24
35. Reducing the Breadth of the Column by Doubling the Gait while at a Trot.....	24
 <u>WHEELINGS</u>	
36. Wheeling in Place.....	25
37. Halting the Wheel.....	25
38. Stopping the Wheel and Continue Marching Forward.....	25
39. To Wheel 90°.....	25
40. To Wheel 180°.....	25
41. To Wheel 45°.....	25
42. Wheeling in Two Ranks.....	28
43. Turning on a Moveable Pivot.....	29
 <u>COMBAT</u>	
44. Mounted Charge.....	30
45. Rallying.....	30
46. Skirmishing.....	31
47. Fighting on Foot.....	32

MANUAL OF ARMS

	PAGE
CARBINE	
48. Carry - Arms	33
49. Order - Arms	33
50. Sling - Carbine	34
51. Unslung - Carbine.....	34
52. Inspection - Carbine.....	35
53. Advance - Carbine (Mounted)	35
54. Drop - Carbine (Mounted)	35
PISTOL	
55. Draw - Pistol	36
56. Return - Pistol	37
57. Inspection - Pistol	37
SABER	
58. Draw - Saber	38
59. Present - Saber	38
60. Carry - Saber.....	39
61. Return - Saber	39
62. Inspection - Saber	40
FORMAL WEAPONS INSPECTION	
63. Inspection of Arms.....	41

INDEX OF FIGURES

FIGURE	PAGE
1. Open Order, Dismounted	4
2. Close Order, Mounted.....	4
3. By the Right - File Off	5
4. By File (From the Right).....	6
5. By Twos (From the Right)	7
6. By Fours (From the Right).....	8
7. Right – Turn (From a Column)	9
8. Right Oblique.....	10
9. Front Into Line	11
10. Left Into Line	13
11. On Right Into Line	15
12. Left Into Single Rank	17
13. Right Into Two Ranks	18
14. Form Twos.....	19
15. Form Fours.....	20
16. By Twos.....	21
17. By File.....	22
18. Wheeling on a Fixed Pivot (In a Single Rank).....	26
19. Wheeling on a Fixed Pivot (In Two Ranks).....	28
20. Turning on a Moveable Pivot (In Line Formation).....	29
21. As Skirmishers	31
22. Linking Horses to Fight on Foot	32
23. Position of Carry - Arms	33
24. Position of Order - Arms	33
25. Slings the Carbine.....	34
26. Unslings the Carbine	34
27. Position of Inspection - Carbine.....	35
28. Position of Advance - Carbine	35
29. Position of Raise - Pistol.....	36
30. Position of Inspection - Pistol	37
31. Drawing the Saber.....	38
32. Position of Present - Saber	38
33. Returning the Saber.....	39

Introduction

The source material for this abbreviated guide comes from *Cavalry Tactics*, (a.k.a. Poinsett's Tactics or simply Poinsett's) as approved by Secretary of War, Joel R. Poinsett in 1841. The original copy of Poinsett's referenced was printed in 1861 by J.B. Lippincott & Co., Philadelphia. This abbreviated guide is not meant to be a definitive interpretation of Poinsett's, but only a simplified (maybe even an over-simplified) guide for training the members of the **2nd US Cavalry Co. A / 9th VA Cavalry Co. D** reenactment group for living history impressions. Not every command or maneuver from the original is included, only the ones most likely to be used by mounted cavalry reenactors.

The author does not hope to claim to be an expert on 19th century cavalry tactics. This guide was written after studying the original drill manuals, and errors in interpretation are inevitable. If you notice an error, or disagree with my interpretation of Poinsett's, please bring it to my attention for correction.



Michael J. Riggleman
Training Committee Chairman
2nd US Cavalry Co. A / 9th VA Cavalry Co. D
mike_riggleman@hotmail.com

General Principles

Text

- All commands (or replies) that are spoken aloud are enclosed in "quotation marks." *Preparatory Commands* are printed in bold italics. **COMMANDS OF EXECUTION** are printed in bold capitals. Non-bold print commands placed inside of parenthesis are for information only and are not spoken aloud.
- The numbers in brackets (e.g. [437]) refer to the paragraph referenced in Poinsett's.
- [Colt Supplement] - refers to the Supplement to Poinsett's, Second Part, page 283 titled, "A *Manual for Colt's Revolver.*"
- Areas that require emphasis are underlined.
- If the command can be given in either direction, this will be noted in the description. For the sake of brevity, illustrations (when provided) will only show the movement in one direction (usually to the right).
- Most of the commands can be given from any of the gaits (walk, trot, or gallop). Exceptions will be noted in the descriptions of the maneuvers.
- The verbal command and proper execution of each maneuver will be fully described the first time that it is presented in this guide. After the first appearance, only the verbal commands given will be listed. For example, the command *Right* – DRESS is used as a part of many movements, and will only be fully described once.

Illustrations

- Arrows represent the facing and placement of the horses.
- The number in the arrow is the number of the trooper after counting fours. (See Paragraph 2)
- A small circle represents a dismounted trooper.
- Shaded figures are the troopers and horses of the front rank.
- White figures are the troopers and horses of the rear rank.
- Dashed or "ghost" figures show beginning or intermediate positions.
- A dashed line shows the path used during the movement – think of them as foot prints.
- A platoon normally has 24 men. To simplify the illustrations, this guide will only show enough troopers to demonstrate the concept.



Flag Notes



Flag Notes are helpful tips, safety notes, historical comments, or memory aids to help you remember the fine points of a command or movement. A Flag Note may also be used to point out, and correct common errors we reenactors have made in the past. Flag Notes are not taken directly from Poinsett's, they are only the observations or suggestions of the author of this guide. Each Flag Note in this guide will be enclosed in a box and highlighted by the flag symbol.

Right in Front vs. Left in Front

Think of a platoon of troopers in a double line formation at close order as being the regular, or most common arrangement. Poinsett's calls this "In natural order." (See drawing B below.) The 1s are to the right, and the 4s are to the left. There are two possible ways these troopers could be arranged in a column: **Right in Front**, or **Left in Front**.

- **Right in Front** means that the troopers that are normally on the right of the "natural" formation (the 1s & 2s) are in front of the column. (See drawing C below.) Right in Front is the normal arrangement for troopers in column.
- **Left in Front** means that the troopers that are normally on the left of the "natural" formation (the 3s & 4s) are in the front of the column. (See drawing A below.) Poinsett's refers to this type of formation as being in inverse order, and states that: "This order should be used only when circumstances require it. "

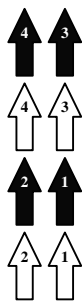

Left in Front

A

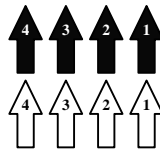

"Natural" Formation

B



Right in Front

C

Left in Front Formations

Poinsett's considered formations with Left in Front as unnatural and for a very good reason, this stuff can get really confusing. Any references to this type of formation should be considered an advanced maneuver and should not be attempted until the unit is highly proficient. For almost every reenactment, there will be little need to use Left in Front formations. A skilled commander can avoid their use by carefully thinking through his commands. In order to give you fair warning, all commands and references to Left in Front in this manual will be enclosed in a dashed box and marked with a skull and cross bones. (See explanation of Left in Front above.)

Terms & Definitions

- A **Rank** is a line of men arranged side by side.
- A **File** is two men, one behind the other.
- A **Line** is a formation with its parts placed one beside another.
- A **Column** is a formation with its parts placed one behind another.
- The **Front** is the direction perpendicular to the alignment of a formation.
- The **Flank** is the right or left side of a formation.
- An **Oblique** is a 22 ½° turn to one side. (Half of a 45° turn.)
- **Dress** means to line up the formation in neatly aligned rows.
- **Guide Right** (or **Guide Left**) means that the trooper in front of the formation on the right (or left) is the guide of the entire formation. All other troopers align themselves on the guide. Each trooper should "feel lightly the boot of the man on the side of the guide" and "yield to all pressure coming from the side of the guide, and resist that coming from the opposite side." [495]
- The **Length of a Horse** is considered to be 3 yards.
- The **Width of a Horse** is considered to be 1 yard.
- The **Near Side**, is the left side of the horse.
- The **Off Side**, is the right side of the horse.
- **Preparatory Commands** are the informational commands given to let you know what is expected, or what's coming next. Usually you do not react to the preparatory command other than to get ready for the command of execution. (The rider prepares his mount for the upcoming movement by "**Gathering the Horse**" - elevating the reins slightly and applying slight pressure with the legs.)
- **Commands of Execution** are the action commands. You react to all commands of execution.
- A **Wheel** is a turn made on a fixed pivot. The inside horse does not move forward, but pivots in place. Wheels are normally used when the troopers are in a line formation.
- A **Turn** is made on a moveable pivot. The inside horse moves slightly forward while turning in a small arc. This arc is 5 paces long for a 90° turn. It is important that turns on a moveable pivot be executed correctly; if the inside horse incorrectly turns on a fixed pivot, all the horses following will get bunched up.
- **Gaits** (Poinsett's calls these **Paces**):
 - Walk** - 100 yards per minute, or about 3 miles per hour.
 - Trot** - 240 yards per minute, or about 8 miles per hour.
 - Gallop** - 300 yards per minute, or about 10 miles per hour. Notice that the gallop is not an uncontrolled, all out run. (The average horse can easily run much faster than 10 miles per hour.) The gait is never increased above the gallop except in the charge.
- When the formation is starting from the halt, and the command does not indicate the gait, the movement is always made at the walk. If already marching, the movement is made with the same gait that the formation is already marching.
- The **Charge** is a direct, quick movement to reach the enemy.
- **Skirmishers** are men dispersed in the front, rear, or on the flanks to cover the movements or position of the rest of the formation.

1. Falling In (With Mounts) [266]

Lead the horse to the assembly area by holding the reins in the right hand, six inches from the bit. When under arms, hook up the saber, and pass the carbine over the right shoulder. Fall into formation at open order, 6 yards between ranks. (See Figure 1.) Once in position, unhook the saber. Stand at attention on the near (left) side of the horse, still holding the reins in the right hand, left hand over the saber. If not carrying weapons, the left hand hangs by the side.

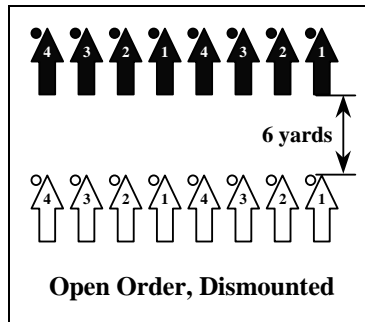

Figure 1

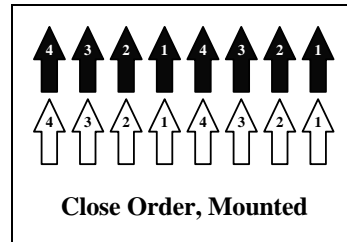

Figure 2

☞ As a general rule, the formation should be kept at open order (6 yards between ranks) whenever the troopers are dismounted. Remember, it's much safer this way since there is less chance of getting kicked.

2. Counting Fours [174]

"In each rank – COUNT FOURS"

Count off, from right to left, in a loud and clear voice: "*one, two, three, four, one, two...*" The front and rear ranks counting together.

☞ As an aid to help this sound more crisp, each trooper turns his head to the right, as in *Right - Dress*, and then turns his head to the front as he sounds off. This way each trooper can anticipate when it is his turn to count off by watching the heads of the men to his right. (This works well if anyone is wearing ear plugs.)

3. Mounting [268]

"PREPARE TO MOUNT"

The numbers 1 & 3 in each rank lead their mounts forward one horse length (six paces). Once they are in place, everyone moves to the near (left) side of their horse and puts their left foot in the stirrup. Wait for the command to mount.

"MOUNT"

Pull yourself into the saddle, place the right foot in the stirrup, and lower the carbine to the right side (suspended from the carbine sling) while keeping the horse still.

"Form – RANKS"

The numbers 2 & 4 gently ride forward and dress to the right. Once each rank is formed, the rear rank moves up to form at close order (two feet behind the front rank).

(See Figure 2 above.)

4. Dismounting [292]

"PREPARE TO DISMOUNT"

The numbers 1 & 3 of the front rank move forward six paces. The numbers 2 & 4 of the rear rank rein back four paces. All pass the carbine over the right shoulder, and remove the right foot from the stirrup. Wait for the command to dismount.

"DISMOUNT"

All dismount on the near (left) side of the horse and hold the reins in the right hand, six inches from the bit.

"Form – RANKS"

The numbers 1 & 3 remain in place. The numbers 2 & 4 of each rank walk forward and dress to the right. Notice that this will leave the formation in open order with one horse length between ranks. (See Figure 1 on page 4.) Stand at attention on the near (left) side of the horse, holding the reins in the right hand, six inches from the bit. Left hand over the saber. If not carrying weapons, the left hand hangs by the side.

5. File Off (After being dismissed.) [293]

"By the right (or By the left) – **FILE OFF"**

Hook up the saber and wait for the command to move.

"MARCH"

The trooper at the right (or left) of each rank leads his horse 4 paces forward and then turns in the direction ordered. Once the first trooper in each rank begins his turn, he is followed successively by the next trooper from the right (or left). Each trooper takes 4 steps forward before turning – Do not pivot in place, you will bunch up everyone behind you.

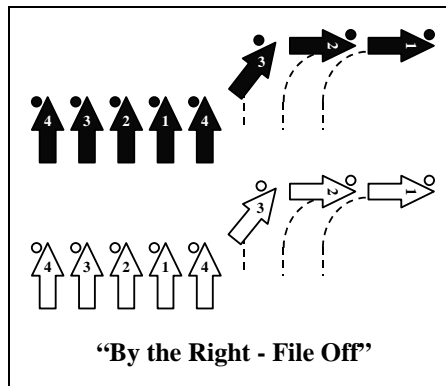

Figure 3

6. Dressing the Formation [425 & 434]

"Right (or left) – **DRESS"**

All troopers turn their head to the right (or left) without turning the shoulders and align themselves by lining up their shoulders with the rider on the right (or left). The troopers on the far right (or left) of each rank do not turn their heads. The troopers in the rear rank should be exactly behind the rider to their front, 2 feet from head to croup. Keep the head turned to the side.

"FRONT"

All turn the head to the front.

7. Opening Ranks (While in Close Order.) [436]

"Rear rank open order"

Rear ranks gathers their horses and waits for the command to move.

"MARCH"

The rear rank reins back 6 paces. The front rank remains in place.

"Right – DRESS"

"FRONT"

See paragraph 6.

8. Closing Ranks (While in Open Order.) [437]

"Rear rank close order"

All gather their horses and wait for the command to move.

"MARCH"

The rear rank moves up to 2 feet from head to croup. Front rank remains in place.

"Right – DRESS"

"FRONT"

See paragraph 6.

9. Break Platoon by File

– (From the right.) [439]

"By file"

Wait for the command to move.

"MARCH"

The first file on the right (number 1s) move straight to the front. As the haunches of the rear number one horse reach the head of the front rank, the next file (number 2s) move 6 paces straight ahead, then obliques (turns 22 ½°) to the right. When the 2s reach their place behind the 1s, they oblique back to the left to line up behind the column. Each file is followed successively by the next file of troopers in line. Each file moves at least six paces forward before obliquing.

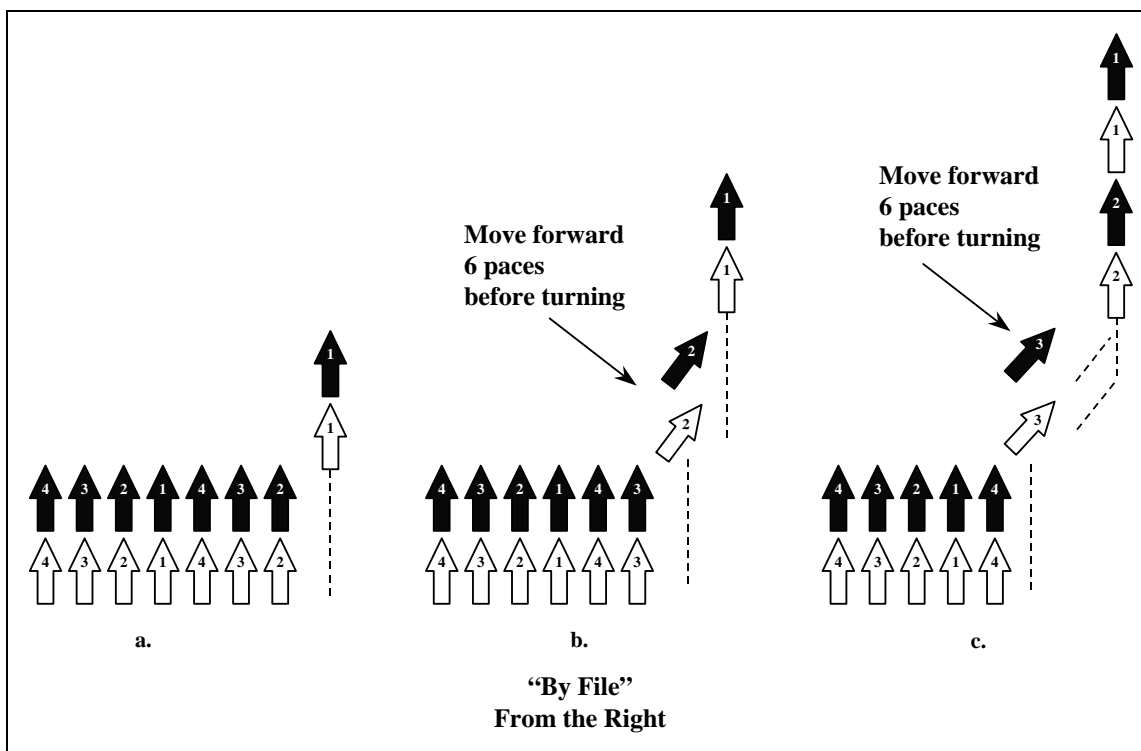

Figure 4

– (From the left.) [441]

"By the left, by file"

"MARCH"

All movements are executed as described in paragraph 9 above, but in the opposite direction.

Keep in mind that a horse is three times as long as it is wide. If a trooper pivots his horse in place without moving forward before turning, the formation will get bunched up.

10. Break Platoon by Twos (or Fours) (From either the halt or while marching.)

– (From the right.) [454 & 533]

"By twos (or By fours)"

Gather the horse and wait for the command to move.

"MARCH"

The first set of twos (or fours) on the right move straight to the front. As the haunches of the horse from the rear rank reach the head of the front rank, the next set of twos (or fours) move 6 paces straight ahead, then obliques (turns 22 ½°) to the right. When each set of twos (or fours) reach their place in line, they oblique back to the left to line up behind the column. Each set of twos (or fours) is followed successively by the next set of twos (or fours) of troopers in line. Each set of twos (or fours) moves at least six paces forward before obliquing.

"Guide left"

This command is called immediately after the command MARCH. All guide off the trooper on the left front of the new formation.

– (From the left.) [455 & 535]

"By twos (or By fours) from the left"

"MARCH"

"Guide right"

All movements are executed as described in paragraph 10 above, but in the opposite direction.

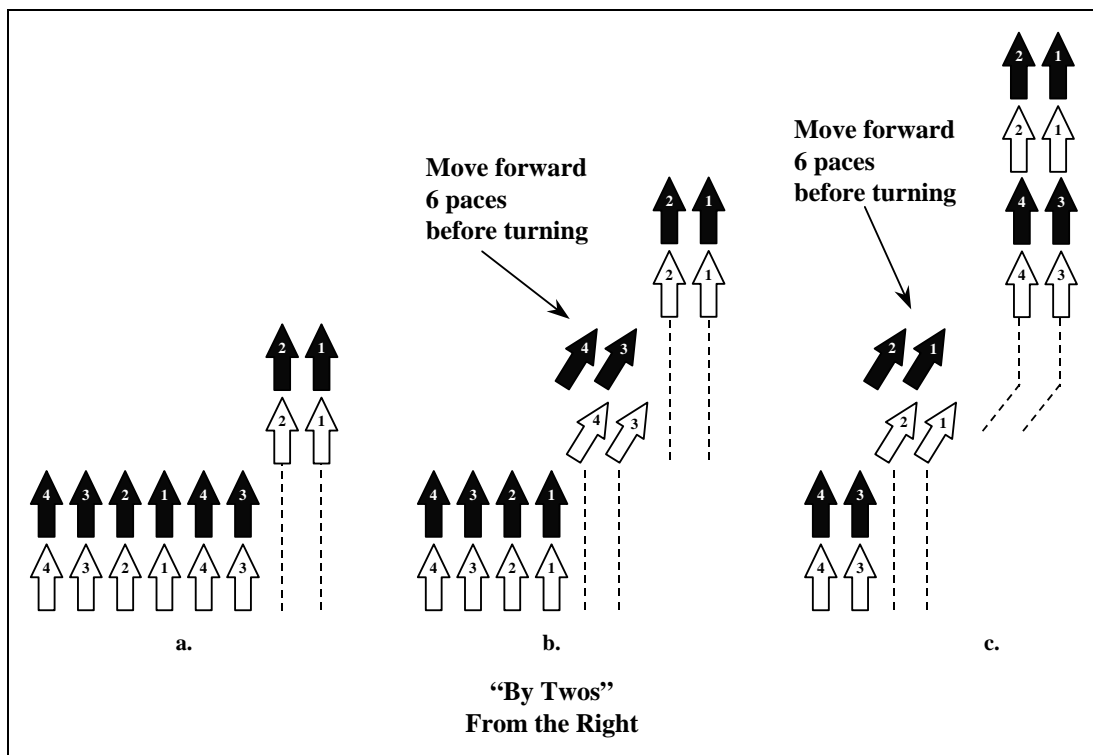

Figure 5

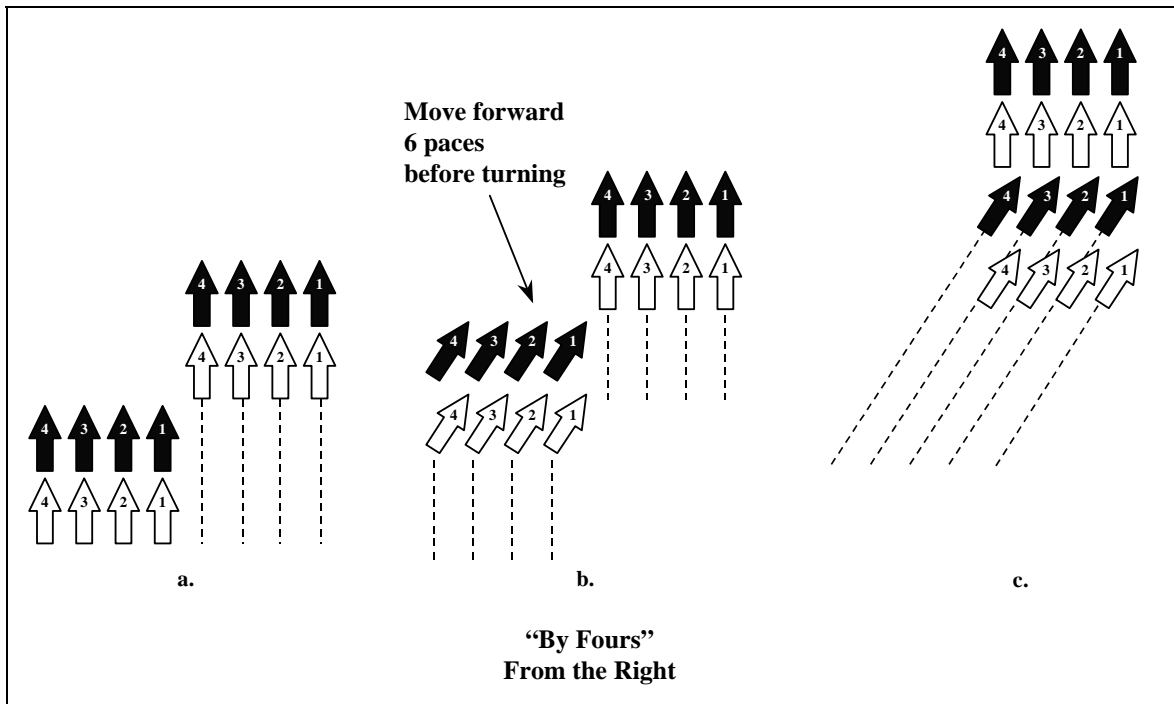

Figure 6

☞ When breaking the platoon from a line formation to a column, the procedures are the same for forming a column of files, twos, or fours. The only difference is that the guide is not called when breaking to a column of files. If you think about it, this makes sense – in a column of files there is no one to your side to dress on. (See Figure 4 on page 6.)

☞ Remember to move forward 6 paces before turning. Keep in mind that a horse is three times as long as he is wide. If a trooper pivots his horse in place without moving forward before turning, the formation will get bunched up.

11. Commence the March at a Walk (While in Column) [445 & 459]

"Column forward"

Gather the horse and wait for the command to move.

"MARCH"

All troopers move off together at a walk.

"Guide left"

All guide off the trooper on the left front of the formation. (The guide is not called if marching in a column of files.)

12. Commence the March at a Trot (While in Column) [446]

"Column forward – trot"

Gather the horse and wait for the command to move.

"MARCH"

All troopers move off together at the trot.

13. Halting the Column (From either the trot or a walk.) [444]

"Column"

Keep moving, but gather the horse and get ready to stop.

"HALT"

All troopers stop together.

14. Turning the Column [457]

"Head of column to the right (or to the left)"

This preparatory command is only given if the commander is not at the head of the column. (See Flag Note below.)

"Right (or Left) – **TURN**"

The first rank of twos or fours turns to the right (or left) on a moveable pivot. The trooper on the inside of the turn remains at his original speed, all other troopers speed up as required to stay in line during the turn. The inside trooper does not immediately pivot his horse in place, he makes a small gradual turn of 5 paces to turn 90°. All continue to turn until FORWARD is called. Each following set of twos or fours continue straight forward until they reach the point on the ground where the head of the column turned, then they turn on a moveable pivot to follow. (Notice there is no MARCH command – The command of execution is TURN.)

"FORWARD"

The troopers at the head of the column stop turning and begin to march straight ahead. All other troopers follow the head of the column, turning when they reach the point on the ground where the head of the column turned. The commander needs to be sure to call FORWARD at the correct time in order to stop the turn when the head of the column is going in the desired direction.

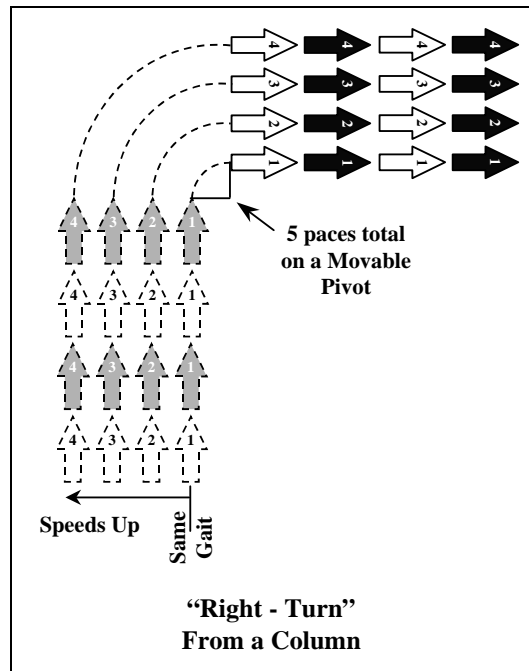

Figure 7

🏰 **"Head of Column"** 🏰

The officer in command of a formation is placed centered in front when the formation is in a line. When the formation is in a column, the commanding officer is placed in the middle of the column, on the left flank. If the column is long, he may not be able to effectively call the commands to turn these at the head of the column. In this case the commander has an assistant (a junior officer, or NCO) riding at the head of the column. When the commanding officer wishes to turn the column, he calls (to his assistant): "*Head of column to the right.*" The assistant then gives the commands "*Right –TURN*" and "*FORWARD*" since these commands need to be called by someone close enough to the head of the column to see what's going on.

15. Obliques [447, 460 & 531]

"Right (or Left) oblique"

Gather the horse and get ready to turn. If moving, keeping marching straight. If at a halt, wait for the command to move.

"MARCH"

Each trooper immediately and simultaneously turns $22\frac{1}{2}^\circ$ to the right (or left) and moves forward in this new direction. Each trooper marches in a line parallel to the other troopers. If the formation is wider than a single file, each trooper places the right (left) knee behind the left (right) knee of the man on the right (left).

"FORWARD"

Turn back $22\frac{1}{2}^\circ$ to the left (or right) and resume marching in the original direction.

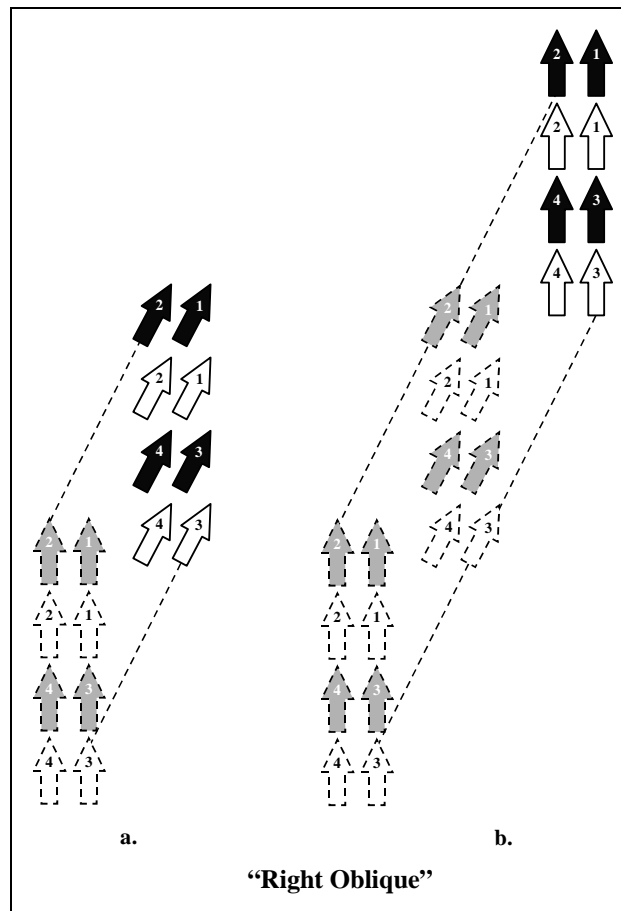

☞ Since all troopers execute each $22\frac{1}{2}^\circ$ turn at the same time, the Oblique can be ordered at any time, regardless of the formation of the troopers. It does not matter if the formation is in line, column of files, twos, or fours. Nor does it matter if in one or two ranks. The most common error made while obliquing is turning 45° instead of only $22\frac{1}{2}^\circ$. Since $22\frac{1}{2}^\circ$ is next to impossible to gauge by eye, you can simply think of an oblique turn as being half of a 45° turn ($45 \div 2 = 22\frac{1}{2}$).

16. Front Into Line (To get from a column, right in front, into double line facing forward.) [448 & 462]

"Front into line"

Gather the horse and get ready to change formation.

"MARCH"

The first file (set of twos/fours) continues straight ahead. All others immediately oblique to the left. Each file (set of twos/fours) continues the oblique until they pass the file (set of twos/fours) in front of them, then they successively oblique back to the right and continue in the original direction.

"HALT"

HALT is called when the first file (set of twos/fours) has marched forward 20 paces. Only the first file (set of twos/fours) halts. All others keep moving until they are in their place on the line.

"Right - DRESS"

The commander calls DRESS immediately after calling HALT. The troopers do not dress until they are in place on the line. Troopers keep their heads turned to the right until FRONT is called.

"FRONT"

All turn the head to the front. (FRONT is not called until all troopers are on line and the formation is dressed.)

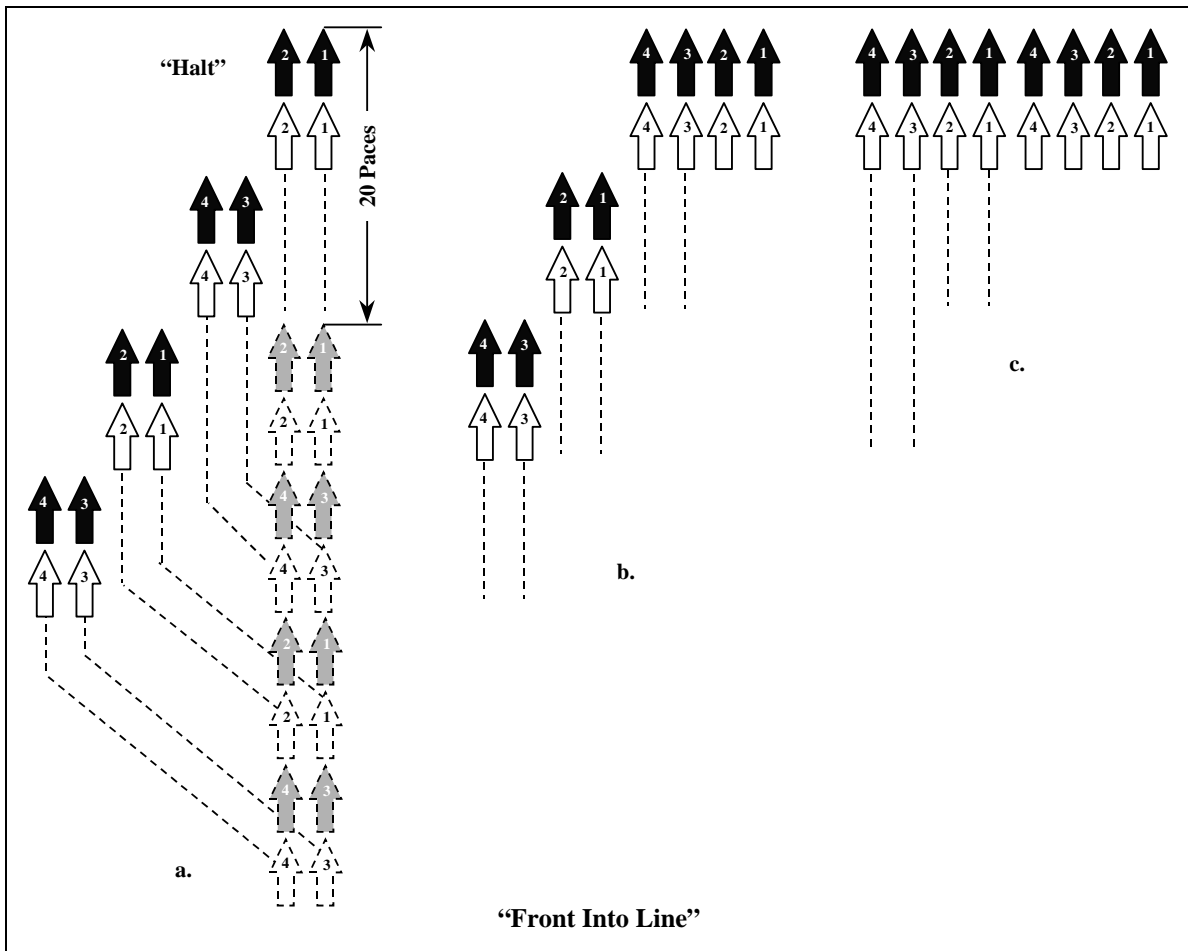

Figure 9



17. Front Into Line (To get from a column, left in front, into a line facing forward.) [449 & 463]

"Front into line"

"MARCH"

"HALT"

"Left - DRESS"

"FRONT"

All movements are executed as described in paragraph 16 above, but in the opposite direction.



 When moving from a column into a line formation all horses are kept at the same gait throughout the change of formation. The rear horses do not speed up. HALT will be called to allow the troopers in the rear of the formation to catch up. Think of it this way – If the formation was already at the gallop, there would be no way to complete this maneuver without somehow slowing the lead horses.

18. Left Into Line (To get from a column, right in front, into a line on the left flank.) [450 & 464]

"Left into line"

Gather the horse and get ready to change formation.

"MARCH"

The first file (set of twos/fours) immediately turns on a moveable pivot 90° to the left and keeps moving. All others continue to march straight ahead until they reach a position just short of where the troopers in front of them turned, then they successively turn to the left.

"HALT"

HALT is called when the first file (set of twos/fours) has marched 20 paces after turning. Only the first file (set of twos/fours) halts. All others keep moving until they are in their place on line.

"Right - DRESS"

The commander calls DRESS immediately after calling HALT. The troopers do not dress until they are in place on the line. Troopers keep their heads turned to the right until FRONT is called.

"FRONT"

All turn the head to the front. (FRONT is not called until all troopers are on line and the formation is dressed.)

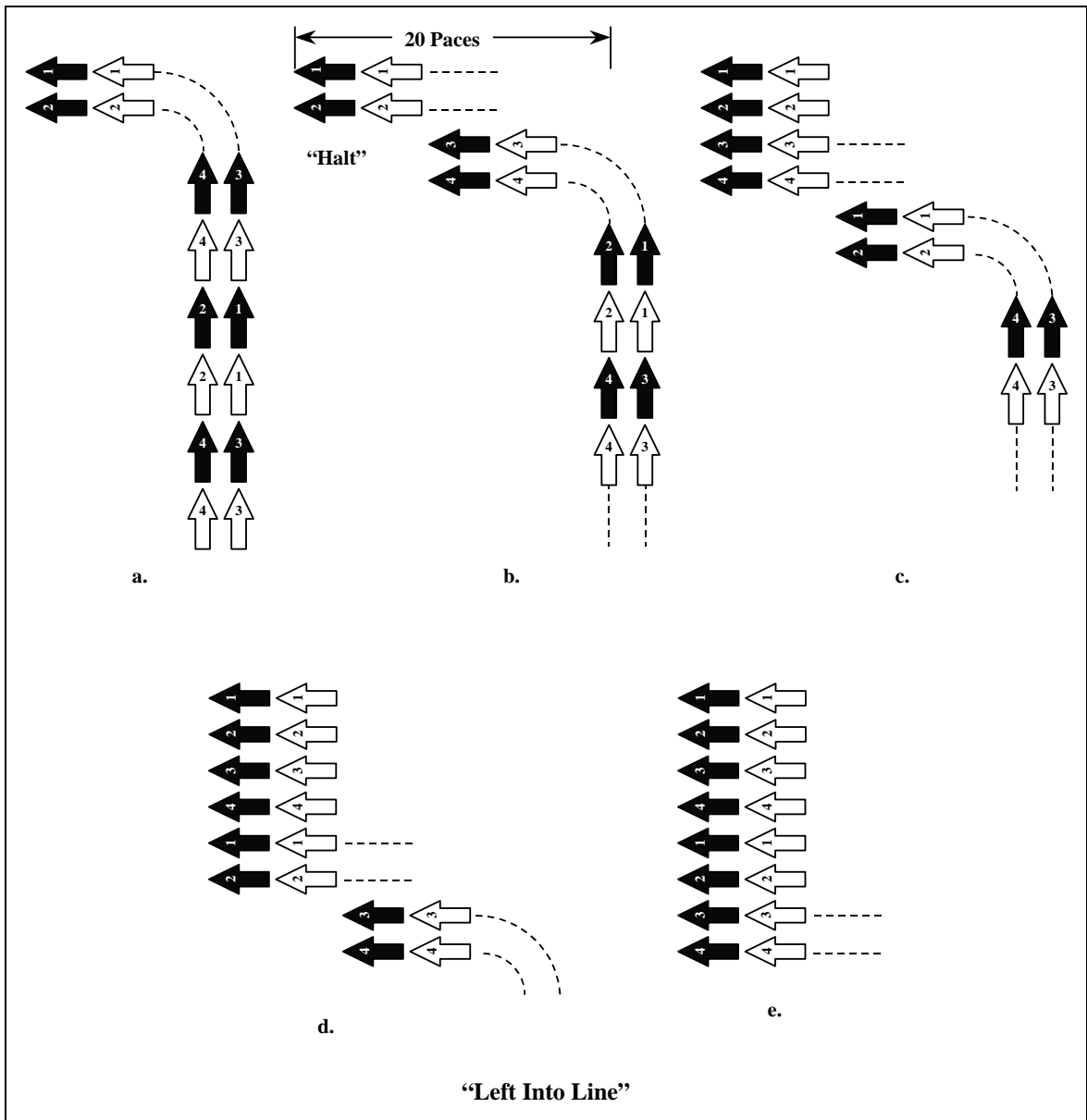

Figure 10

19. Right Into Line (To get from a column, left in front, into a line on the right flank.) [451 & 465]

<p>"Right into line" "MARCH" "HALT" "Left - DRESS" "FRONT"</p>	<p>All movements are executed as described in paragraph 18 above, but in the opposite direction.</p>
---	--

¶ When moving from a column into a line formation all horses are kept at the same gait throughout the change of formation. The rear horses do not speed up. HALT will be called to allow the troopers in the rear of the formation to catch up. Think of it this way – If the formation was already at the gallop, there would be no way to complete this maneuver without somehow slowing the lead horses.

20. On Right Into Line (To get a column, right in front, into a line ahead of the right flank.) [452 & 466]

"On right into line"

Gather the horse and get ready to change formation.

"MARCH"

The first file (set of twos/fours) turns on a moveable pivot 90° to the right and keeps moving. All others continue to march straight ahead until they pass by the file (set of twos/fours) in front of them, then they successively turn to the right.

"HALT"

HALT is called when the first file (set of twos/fours) has marched 20 paces after turning. Only the first file (set of twos/fours) halts. All others keep moving until they are in their place on the line.

"Right – DRESS"

The commander calls DRESS immediately after calling HALT. The troopers do not dress until they are in place on the line. Troopers keep their heads turned to the right until FRONT is called.

"FRONT"

All turn the head to the front. (FRONT is not called until all troopers are on line and the formation is dressed.)

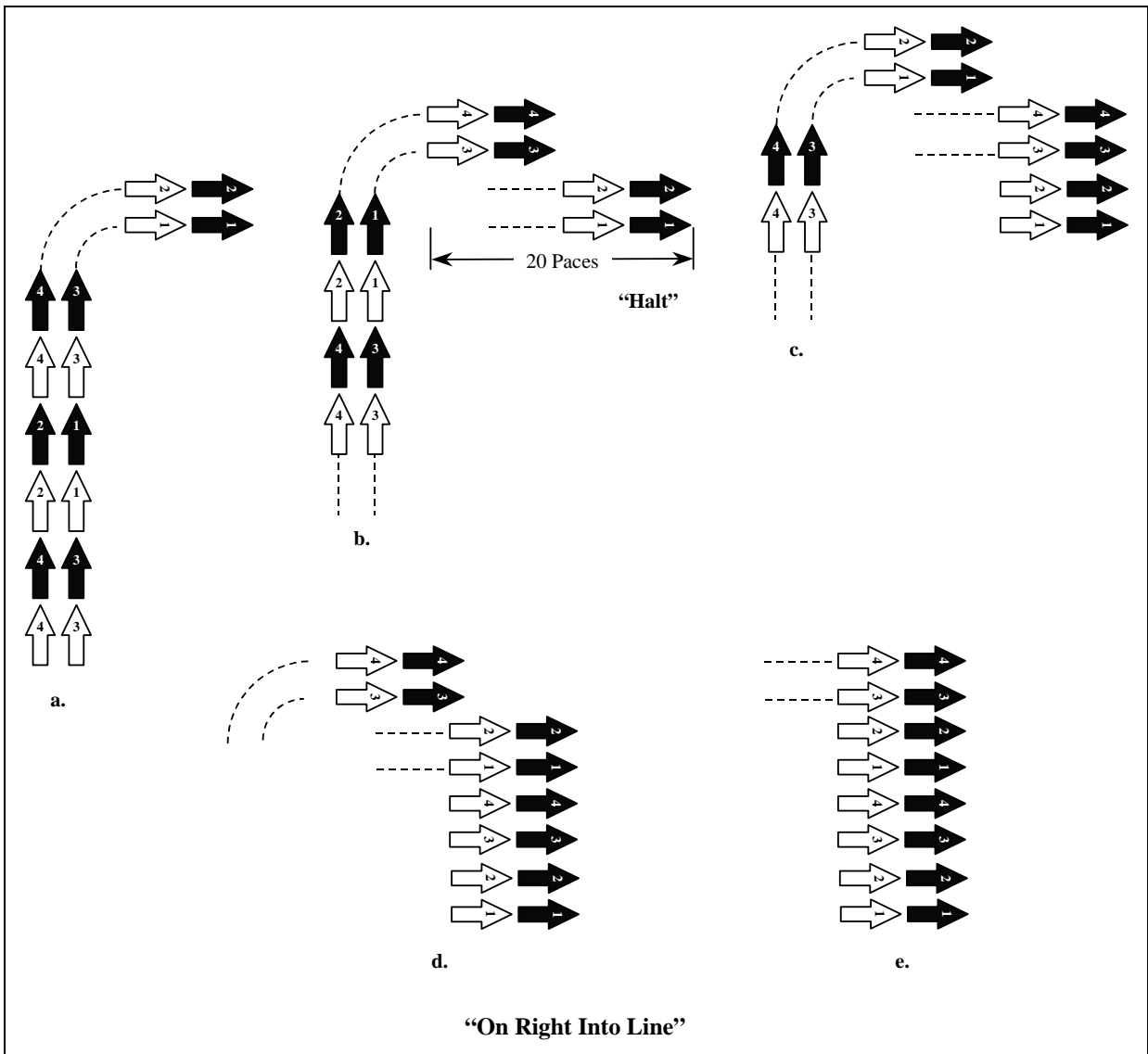

Figure 11

Xe

21. **On Left Into Line** (To a column, left in front, to a line ahead of the left flank.) [453 & 467]

"On left into line"

"MARCH"

"HALT"

"Left – DRESS"

"FRONT"

All movements are executed as described in paragraph 20 above, but in the opposite direction.

Xe

Xe

Xe

When moving from a column into a line formation all horses are kept at the same gait throughout the change of formation. The rear horses do not speed up. HALT will be called to allow the troopers in the rear of the formation to catch up. Think of it this way – If the formation was already at the gallop, there would be no way to complete this maneuver without somehow slowing the lead horses.

Keeping Commands Straight in Your Mind

Commands like *Front into line*, *Left into line*, and *On left into line* sound very similar, and are often hard to keep straight in your mind. It may help to mentally divide up the area around the formation into the sections shown in the illustration below. Then as the commander calls a given order – picture in your mind where the formation will end up at the end of the maneuver. This way you can easily answer questions like – Do I turn before or after the lead troopers when the command is *Left into line*?

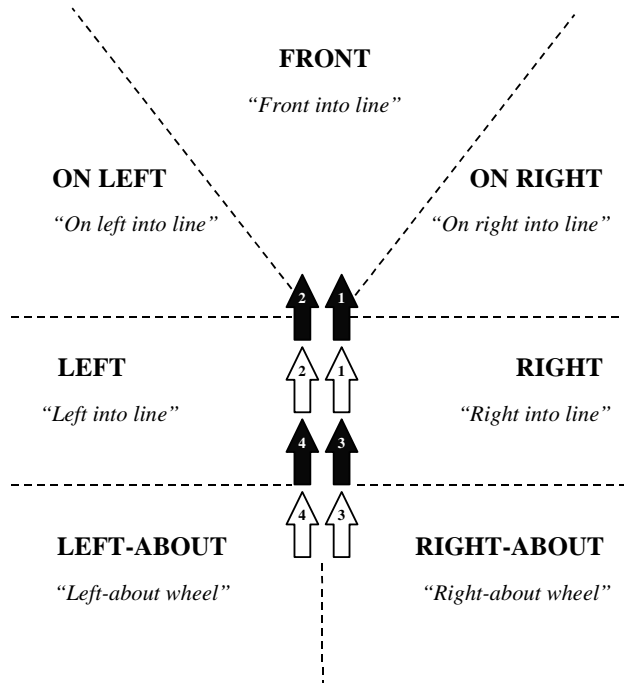

22. Moving from Two Ranks to a Single Rank [469]

"Left into single rank"

Gather the horse and get ready to change formation.

"MARCH"

The front rank moves forward 6 paces and halts. The trooper on the far left of the rear rank moves forward slightly and then turns to the left and moves forward in this new direction; he is successively followed by all other troopers of the rear rank.

"FRONT"

The lead trooper of the rear rank immediately turns to the right. The others on the rear rank continue until they reach their position on the line before successively turning to the right. (Since the rear rank will not be able to see behind them to tell when to turn back to the front, the commander will have to watch closely to call FRONT at the correct time.)

"HALT"

The trooper on the far left of the rear rank halts. All others continue until they have reached their position on the line. (Again, the commander will have to watch closely to call HALT at the correct time.)

"Right – DRESS"

"FRONT"

See paragraph 6.

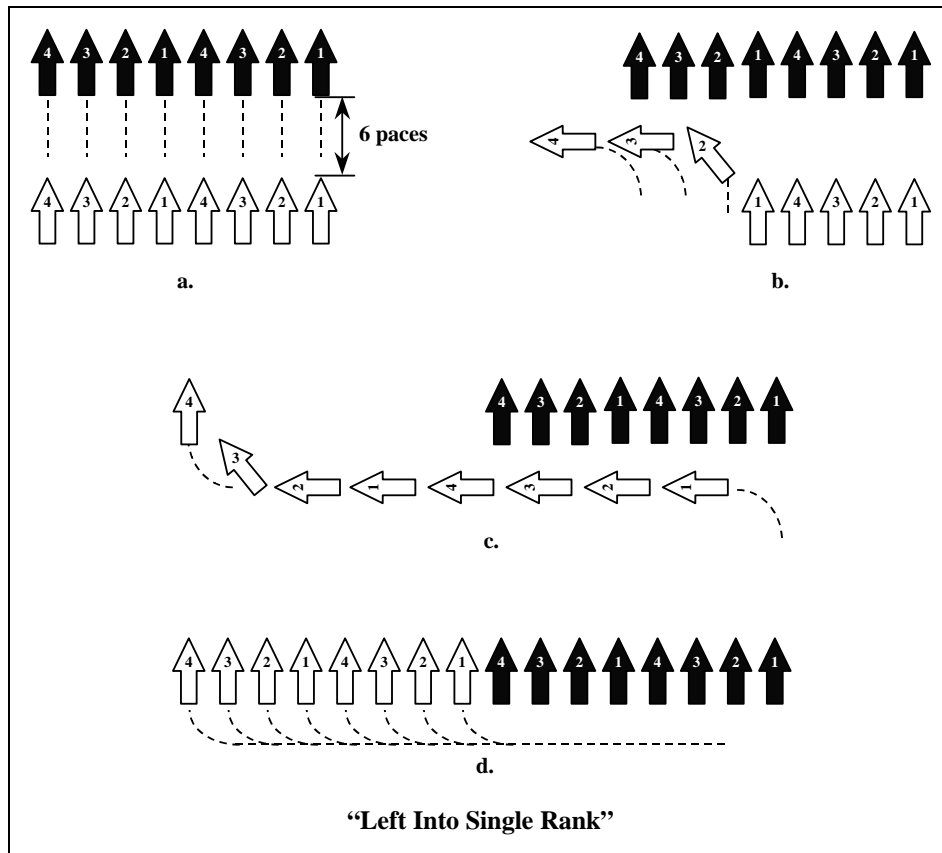

Figure 12

23. Moving from a Line in a Single Rank to Double Ranks [471]

"Right into two ranks"

Gather the horse and get ready to change formation.

"MARCH"

The front rank moves forward 6 paces and halts. As soon as the front rank is out of the way, the trooper on the far right of the rear rank moves forward slightly and then turns to the right and moves forward in this new direction; he is successively followed by all the other troopers of the rear rank. As the first trooper in the rear rank comes up behind the first trooper in the front rank, he turns to the left and takes his position with two feet from head to croup. The other troopers in the rear rank successively turn to the left and take their positions. (Notice that since the rear rank can see when they are in position, there are no additional commands for them to turn back to the front.)

"Right - DRESS"

DRESS is called when the first trooper in the rear rank is in position. The troopers in the front rank immediately dress. The troopers of the rear rank continue moving to their correct positions, and dress once they are in place.

"FRONT"

All turn the head to the front.

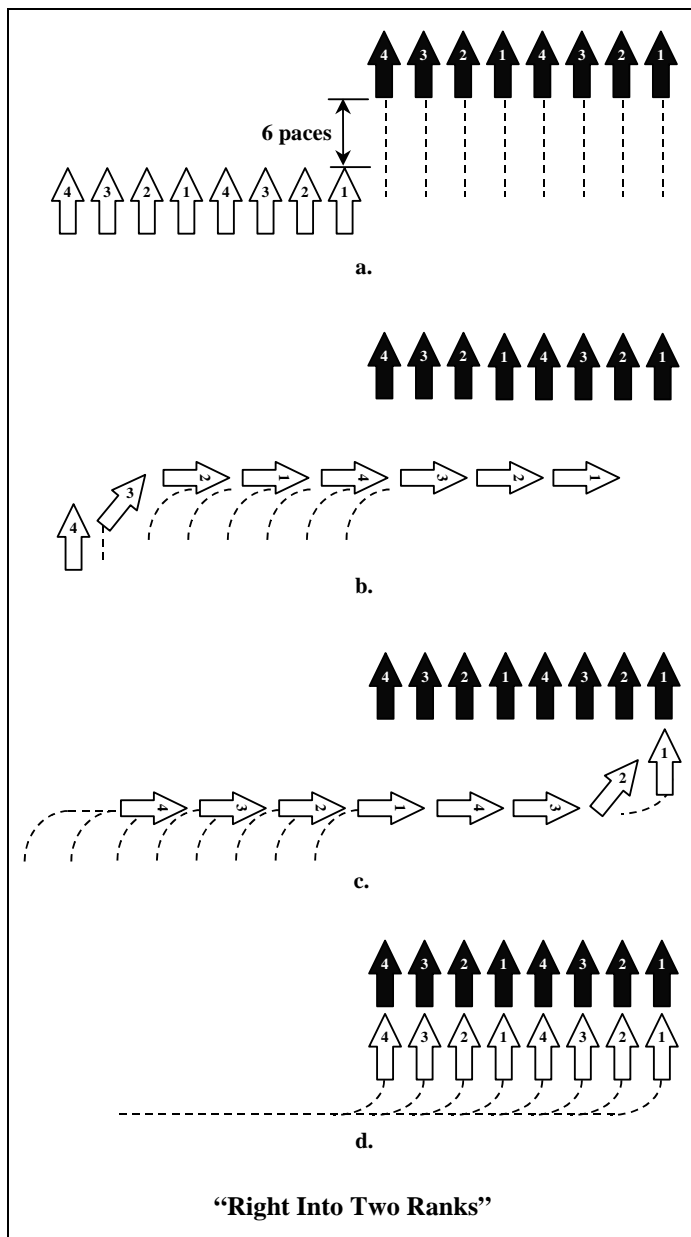

Figure 13

Changing the Breadth of the Column

There are two ways to change the breadth of a column on the march: At the same gait, or by doubling the gait. To increase the breadth at the same gait requires that the lead troopers slow down one gait (or stop if at a walk) to let the other troopers catch up. In doubling the gait, the lead troopers maintain the current gait and the other troopers speed up one gait to catch up. To reduce, or break the breadth of the column at the same gait, requires that the rear troopers slow down one gait (or stop if at a walk). In doubling the gait, the lead troopers speed up one gait in order to stretch out the formation and the other troopers speed up once they are in place.

Why do some commands start with "By" and others with "Form"

The command *Form* (as in "*Form fours*") means to increase the breadth of the column. The command *By* (as in "*By twos*") means to reduce, or break, the breadth of the column. With this in mind, it's easy to remember the correct command. If in a column of twos, the correct commands would be "*Form fours*" (to increase the breadth of the column) and "*By file*." (to reduce the breadth of the column). In this example, "*By fours*" would not be correct since you are increasing, not reducing the breadth of the column.

24. Column of Twos from a Column of Files (At the Same Gait, While at the Walk.) [473]

"Form twos"

Gather the horse and get ready to change formation.

"MARCH"

The first file (the number 1s) marches forward 10 paces then halts. The second file (number 2s) immediately oblique to the left, then turn back to the right in order to halt in line with the first file. All remaining troopers continue forward. The next file in column (number 3s) halt two feet behind the ones. The fours wait until they are just behind 3s, oblique to the left and then turn right to line up beside the 3s. These movements are successively repeated, the number 1s & 3s staying in line, the number 2s & 4s obliquing left, until all are in position and halted. (Notice that the number 2s & 4s do not oblique simultaneously, they continue forward and oblique in sequence.)

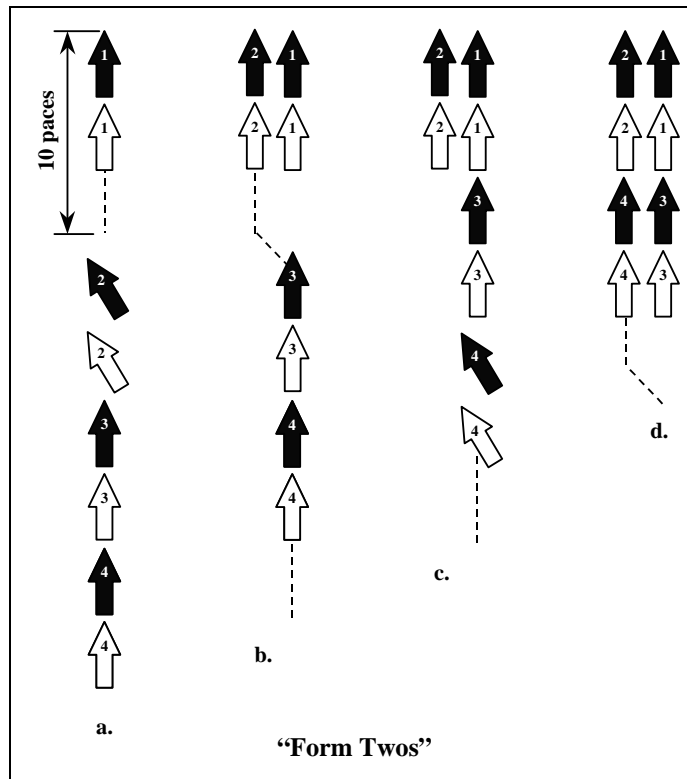

Figure 14

25. Column of Fours from a Column of Twos (At the Same Gait, While at the Walk.) [474]

"Form fours"

Gather the horse and get ready to change formation.

"MARCH"

The first two files (number 1s & 2s) march forward 10 paces then halt. The second set of files (number 3s & 4s) immediately oblique to the left, then turn back to the right in order to halt in line with the number 1s & 2s. All remaining troopers continue forward. The second set of number 1s & 2s halt two feet behind the first. The next set of number 3s & 4s wait until they are just behind the second set of 1s & 2s then oblique to the left and then turn right to line up with them. These movements are successively repeated, the number 1s & 2s staying in line, the number 3s & 4s obliquing left, until all are in position and halted. (Notice that the number 3s & 4s do not oblique simultaneously, they continue forward and oblique in sequence.)

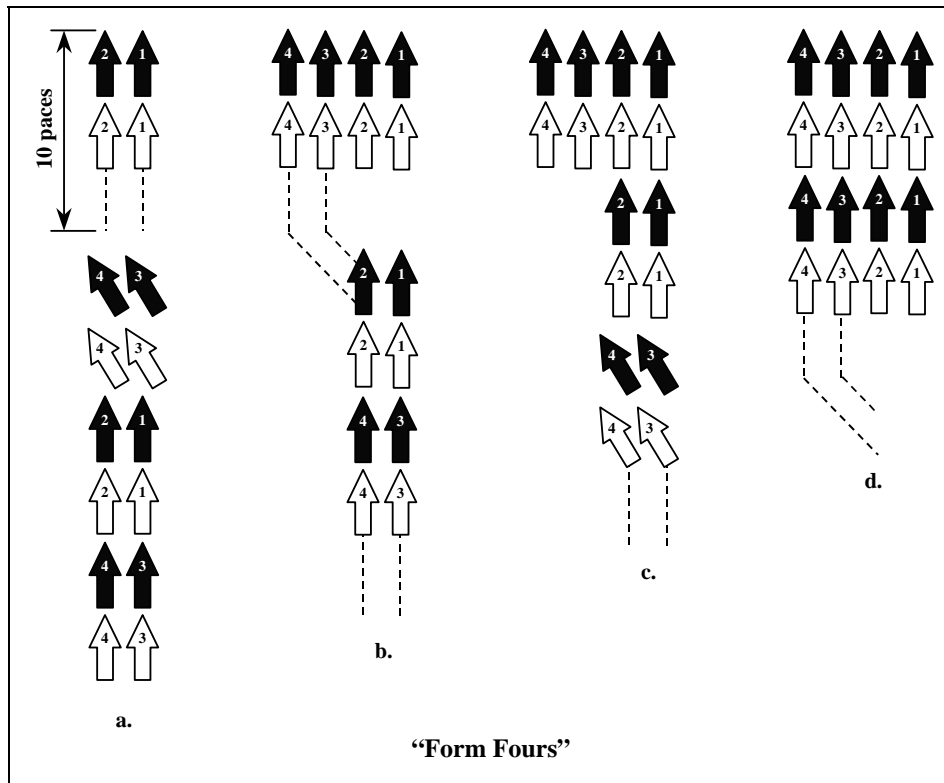

Figure 15

26. Increasing the Breadth of the Column at the Same Gait. [475]

If at a trot.

All the same principles as described in paragraphs 24 & 25 remain the same except the leading files/twos slow to a walk. All others remain at a trot until they are in position, then they also slow to a walk.

If at a gallop.

All the same principles as described in paragraphs 24 & 25 remain the same except the leading files/twos slow to a trot. All others remain at a gallop until they are in position, then they also slow to a trot.

27. By Twos from a Column of Fours (At the Same Gait, While at the Walk.) [476]

"By twos"

Gather the horse and get ready to change formation.

"MARCH"

The leading number 1s & 2s continue to march forward at the same gait. All other troopers halt. Once the leading number 1s & 2s are out of the way, the leading number 3s & 4s oblique to the right and take up their position in the column behind the leading number 1s & 2s. Once the leading set of 3s & 4s are in place, the next set of 1s & 2s move forward – once they are in place, they are followed by the next set of 3s & 4s which oblique to the right to take up their positions. This sequence is repeated until all are in a column of twos, moving forward at a walk.

"Guide left"

All guide off the trooper on the left front of the formation.

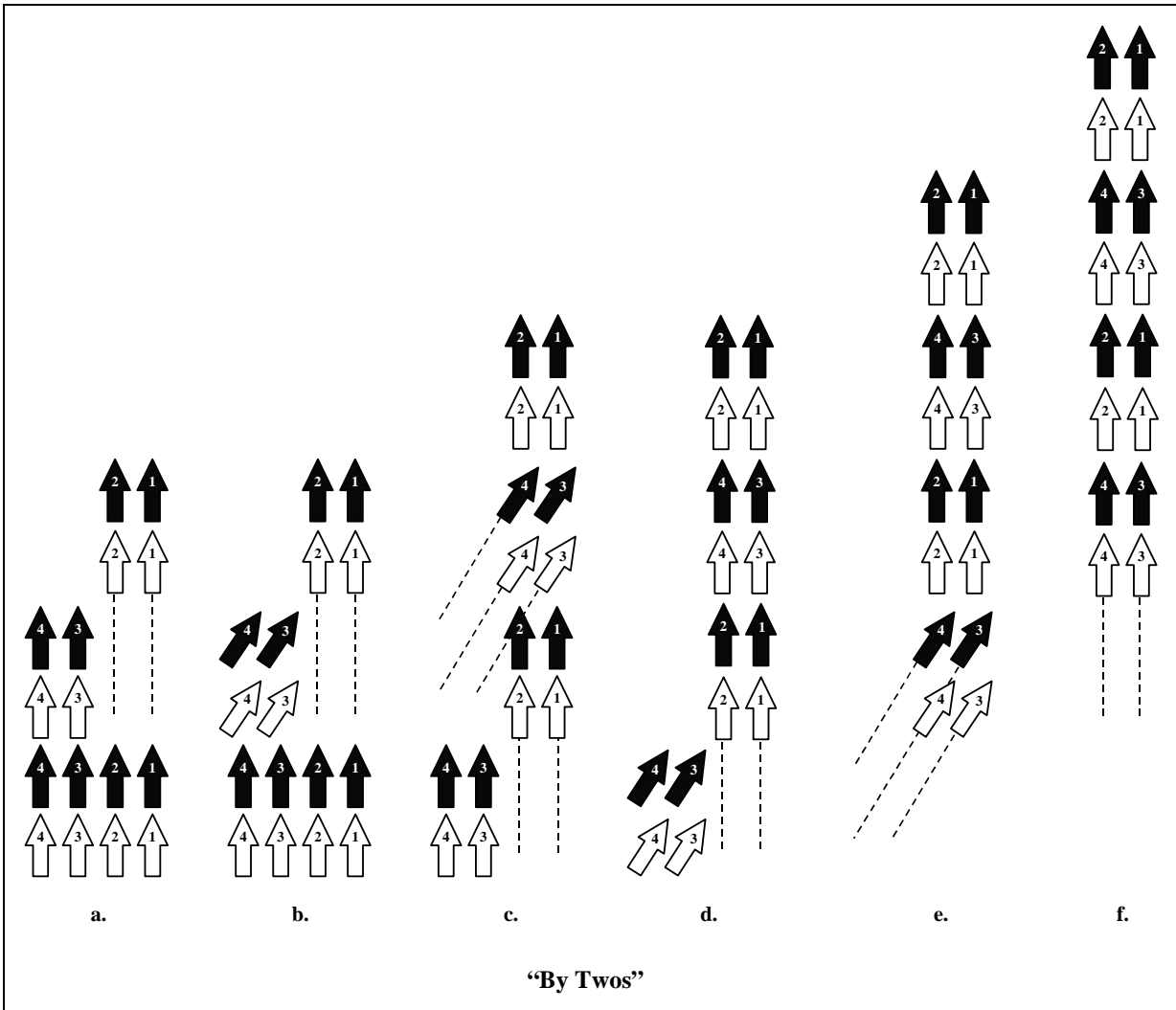

Figure 16

28. By File from a Column of Twos (At the Same Gait, While at the Walk.) [477]

"By file"

Gather the horse and get ready to change formation.

"MARCH"

The first set of number 1s continue to march forward at the same gait. All other troopers halt. Once the leading number 1s are out of the way, the leading number 2s oblique to the right and take up their position in the column behind the leading number 1s. Once the leading set of 2s are in place, the first set of 3s move forward – once they are in place, they are followed by the first set of 4s which oblique to the right to take up their positions. This sequence is repeated until all are in a column of files, moving forward at a walk.

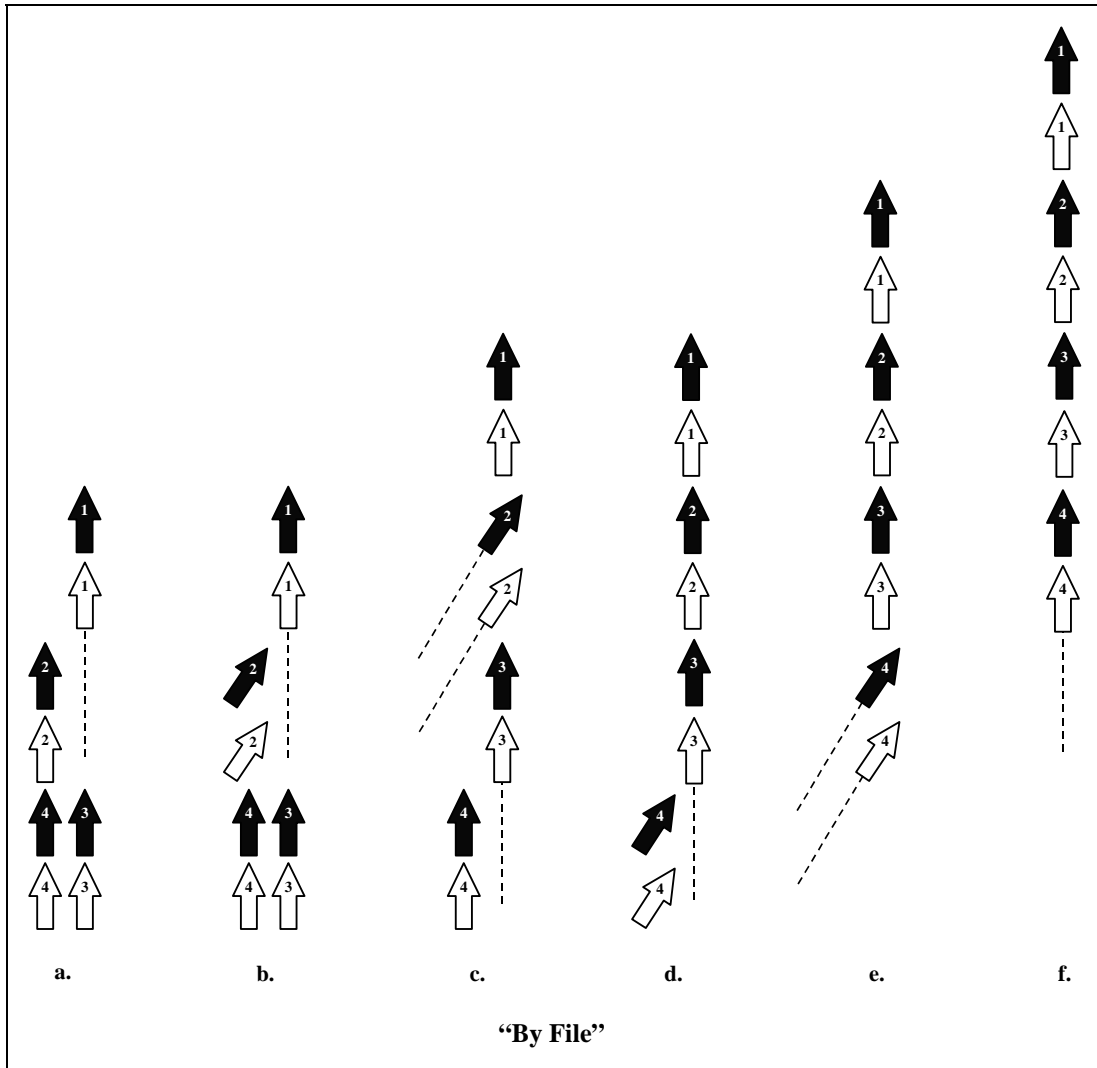

Figure 17

29. Reducing the Breadth of the Column at the Same Gait [478]

If at a trot.

All the same principles as described in paragraphs 27 & 28 remain the same except the leading files/twos continue at a trot. All others slow to a walk until they are in position, then they return to the trot.

If at a gallop.

All the same principles as described in paragraphs 27 & 28 remain the same except the leading files/twos continue at a gallop. All others slow to a trot until they are in position, then they return to the gallop.

30. Column of Twos from a Column of Files (Doubling the Gait.) [480] (See Figure 14 on page 19.)

"Form twos – trot"

Gather the horse and get ready to change formation.

"MARCH"

The first file (the number 1s) continue marching forward at the walk. All others speed up to a trot. The second file (number 2s) immediately oblique to the left, then turn back to the right in order to slow to a walk once abreast of the leading number 1s. All remaining troopers continue forward at a trot. The next file in column (number 3s) slow to a walk as they approach behind the 1s. The 4s wait until they are just behind the 3s, oblique to the left and then turn right and slow to a walk once abreast of the 3s. These movements are successively repeated, the number 1s & 3s staying in line, the number 2s & 4s obliquing left, until all are in position and moving forward at a walk. (Notice that the number 2s & 4s do not oblique simultaneously, they continue forward and oblique in sequence.)

"Guide left"

All guide off the trooper on the left front of the formation.

31. Column of Fours from a Column of Twos (Doubling the Gait.) [481] (See Figure 15 on page 20.)

"Form fours – trot"

Gather the horse and get ready to change formation.

"MARCH"

The first set of twos in column (first number 1s & 2s) continue marching forward at the walk. All others speed up to a trot. The second set of twos (first number 3s & 4s) immediately oblique to the left, then turn back to the right and slow to a walk once abreast of the lead set of twos. All remaining troopers continue forward at a trot. The next set of twos in column (second 1s & 2s) slow to a walk as they approach behind the head of the column. The fourth set of twos (second 3s & 4s) continue forward at a trot until they are just behind the second 1s & 2s, oblique to the left and then turn right and slow to a walk once abreast of the second 1s & 2s. These movements are successively repeated, the number 1s & 2s staying in line, the number 3s & 4s obliquing left, until all are in position and moving forward at a walk. (Notice that the number 3s & 4s do not all oblique simultaneously, they continue forward and oblique in sequence.)

³**"Guide left"**

All guide off the trooper on the left front of the formation.

32. Increasing the Breadth of the Column in Doubling the Gait from the Trot [482]

"Form fours – gallop"

Gather the horse and get ready to change formation.

"MARCH"

All the same principles as described in paragraphs 30 & 31 remain the same expect that the leading files/twos remain at a trot while all others speed up to a gallop. All return to a trot once in place.

- If at a gallop, these maneuvers must be done at the same gait – the gait is not increased above the gallop. (See paragraph 26.)

33. By Twos from a Column of Fours (Doubling the Gait) [485] (See Figure 16 on page 21.)

"By twos – trot"

Gather the horse and get ready to change formation.

"MARCH"

The leading number 1s & 2s speed up to a trot. All other troopers remain at a walk. Once the leading number 1s & 2s are out of the way, the leading number 3s & 4s oblique to the right at a trot and take up their position in the column behind the leading number 1s & 2s. Once the leading number 3s & 4s are in place, the second 1s & 2s trot forward – once they are in place, they are followed by the next number 3s & 4s which oblique to the right at a trot to take up their positions. This sequence is repeated until all are in a column of twos, moving forward at a trot.

"Guide left"

All guide off the trooper on the left front of the formation. (Notice that all troopers will now be at the trot. The commander must order the troopers to a walk if he wants to slow back down.)

34. By File from a Column of Twos (Doubling the Gait) [486] (See Figure 17 on page 22.)

"By file – trot"

Gather the horse and get ready to change formation.

"MARCH"

The leading number 1s in column speed up to a trot. All other troopers remain at a walk. Once the number 1s are out of the way, the number 2s speed up to a trot and oblique to the right and take up their position in the column behind the number 1s. Once the 2s are in place, the 3s speed up to a trot – once they are in place, they are followed by the 4s which speed up to a trot and oblique to the right to take their positions. This sequence is repeated until all are in a column of files, moving forward at a trot. (The commander must order the troopers to a walk if he wants to slow back down.)

35. Reducing the Breadth of the Column by Doubling the Gait while at a Trot [478]

"By twos (or By file) – gallop"

Gather the horse and get ready to change formation.

"MARCH"

All the same principles as described in paragraphs 33 & 34 remain the same except that the troopers will speed up to a gallop to complete the maneuvers.

- Since you do not speed up past the gallop, the only way to break the column to a narrower front, while at the gallop, is at the same gait. (See paragraph 29.)

36. Wheeling in Place (While in a single rank.) [513] (See Figure 18A)

"Platoon (Squad or Company) in circle right (or left) wheel"

Gather the horse and get ready to change formation.

"MARCH"

All begin to turn to the right together. The inside trooper pivots in place on a fixed pivot. The outside trooper remains at the original gait. All other troopers regulate their speed to stay in line. Each trooper should look to the outside of the wheel to control their speed, and keep close to the trooper on the inside of the turn to control their spacing. (You can remember how to keep your place by thinking of the phrase "Look out and lean in.") The formation continues to wheel until the commander stops the maneuver. (Continuously wheeling in place is used for training only.)

37. Halting the Wheel [514]

"Platoon (Squad or Company)"

Gather the horse and get ready to change formation.

"HALT"

All troopers halt in line.

"Left (or Right) – DRESS"

The commander should wait until the trooper on the outside of the turn is abreast of the pivot man before dressing the formation. Dress is always called towards the outside of the wheel, i.e. dress left after a right wheel. (See paragraph 6 for a description of how to dress the formation.)

"FRONT"

All turn the head to the front.

38. Stopping the Wheel and Continue Marching Forward [515]

"FORWARD"

All troopers stop turning and move forward at the original gait.

"Guide left (or Right)"

All guide off the trooper on the left (or right) front of the formation. The guide is always called towards the outside of the wheel, i.e. guide left after a right wheel.

39. To Wheel 90° [523] (See Figure 18C)

"Platoon (Squad or Company) right (or left) wheel"

"MARCH"

"HALT"

"Left (or Right) – DRESS"

"FRONT"

See paragraph 6.

40. To Wheel 180° [524] (See Figure 18D)

"Platoon (Squad or Company) right-about (or left-about) wheel"

"MARCH"

"HALT"

"Left (or Right) – DRESS"

"FRONT"

See paragraph 6.

41. To Wheel 45° [525] (See Figure 18B)

"Platoon (Squad or Company) right-half (or left-half) wheel"

"MARCH"

"HALT"

"Left (or Right) – DRESS"

"FRONT"

See paragraph 6.

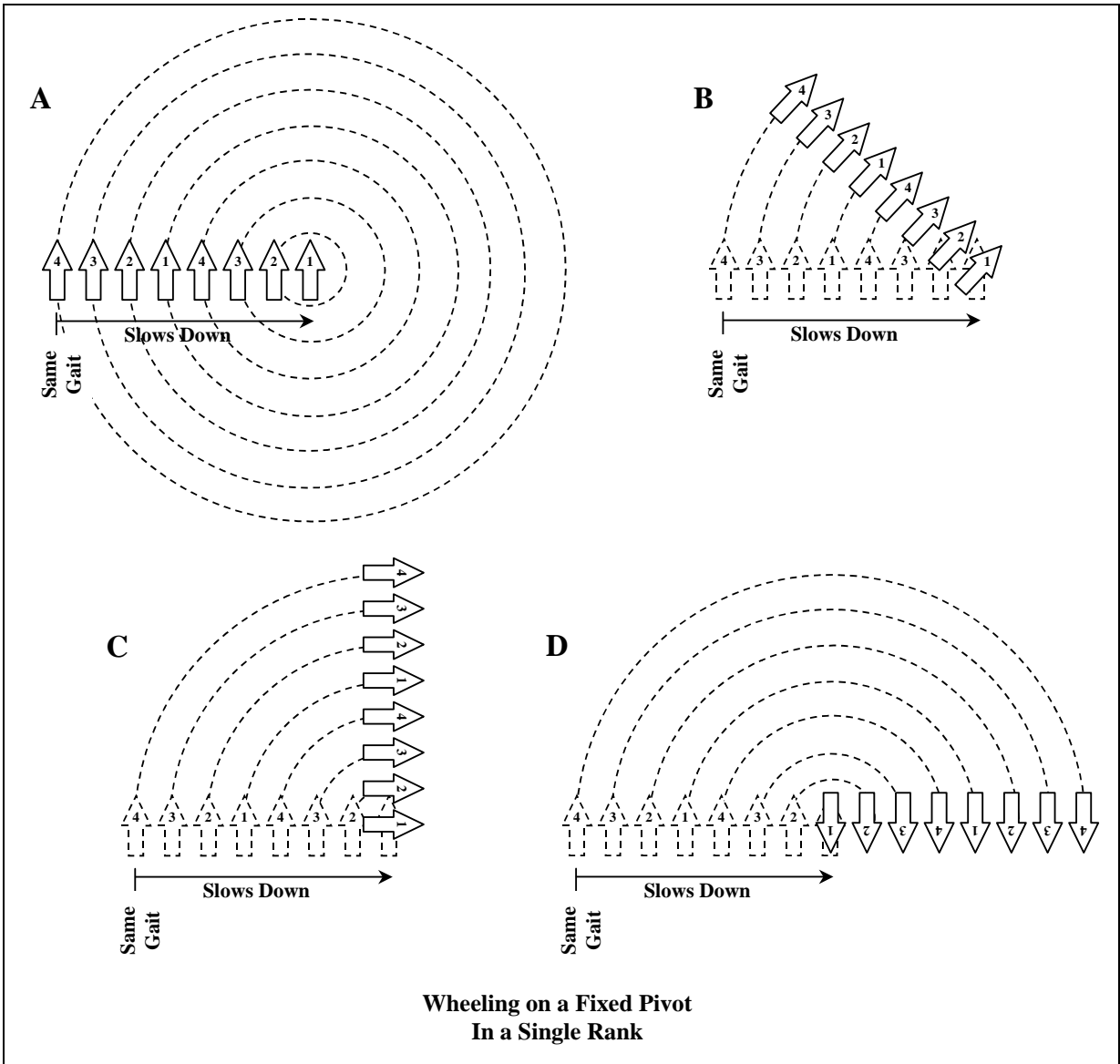

Figure 18

🔗 Wheelings 🔗

There are two kinds of wheelings, on a fixed pivot and on a moveable pivot.

Fixed Pivot

The inside horse does not move forward, but pivots in place. When the commander requires a turn on a fixed pivot he will use the word "Wheel" in his command i.e. "*Right Wheel* – MARCH." The turn on a fixed pivot is executed by the trooper on the inside of the turn (the pivot man) halting and pivoting in place. The trooper on the outside of the turn remains at his original speed. All other troopers will regulate their speed, according to their position, in order to stay in line.

Moveable Pivot

The inside horse moves slightly forward while turning in a small arc. (This arc is 5 paces long for a 90° turn.) . When the commander requires a turn on a moveable pivot he will use the word "Turn" in his command i.e. "*Right* –TURN." It's important that turns on a moveable pivot be executed correctly, if the inside horse pivots in place, all the horses following will get bunched up. The trooper in the center of the front rank remains at the original speed. The troopers toward the outside of the turn will speed up, and the troopers toward the inside will slow down. All troopers will regulate their speed, according to their position, in order to stay in line.

The commander should wait until the trooper on the outside of the turn is abreast of the pivot man before dressing the formation. If DRESS is called before the outside trooper is on line, the rest of the formation will have to rein back to dress. DRESS is always called towards the outside of the wheel, i.e. dress left after a right wheel. To give the troopers a little time to react, HALT or FORWARD should be called a little before the point where the commander wants the turn to stop.

The troopers should not stop turning until ordered, but they can anticipate how far to turn from the preparatory command given:

"In circle right wheel" – A continuous wheel in place until stopped. (Used for training only.)

"Right wheel" – Anticipate a 90° turn.

"Right-about wheel" – Anticipate a 180° turn to the rear.

"Right-half wheel" – Anticipate a 45° turn.

42. Wheeling in Two Ranks [518 & 519]

The front rank follows the directions in paragraph 36. The rear rank makes a slight turn ($22\frac{1}{2}^\circ$) toward the outside and aligns behind the trooper two places over. The two troopers on the outside of the turn will not be behind any trooper in the front rank and adjust their speed as required to stay in line. The rear rank remains facing slightly to the outside until just before the commander stops the turn. In effect, the rear rank turns on a moveable pivot while the front rank turns on a fixed pivot. The rear rank returns to their original positions on the first word of the command to stop the wheel. (For example, if the command to stop is "Platoon – HALT," the rear rank returns to their original positions at the word "Platoon.")

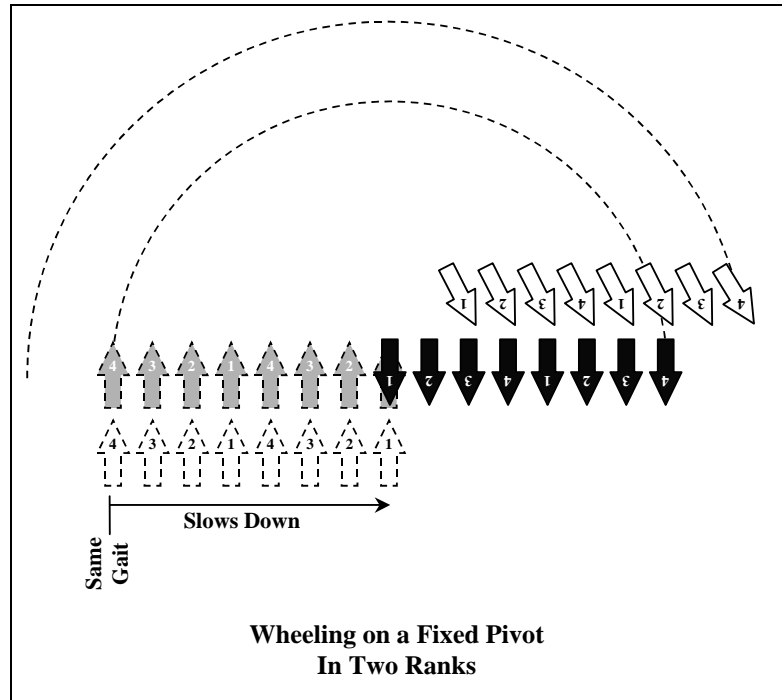
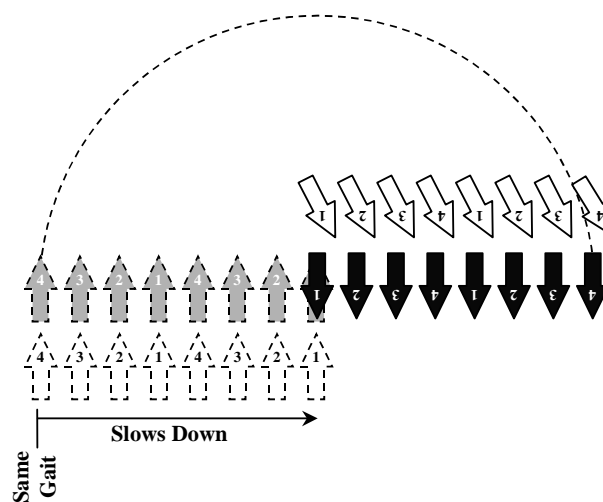

Figure 19

⌘ Keeping the alignment of all troopers tight while wheeling with two ranks is one of the most difficult, and most often poorly executed, of all drill maneuvers. Here is a slight deviation from Poinsett's that works well for the smaller units that are more commonly seen during reenactments: Follow paragraph 42 above, except the rear rank remains in place and turns $22\frac{1}{2}^\circ$ towards the outside of the turn, keeping their alignment by pointing at the front rank trooper that is one place towards the outside. It is critical that the trooper on the outside of the turn not speed up, but maintain the original gait throughout the turn. All other troopers must regulate their speed on the outside trooper.



43. Turning on a Moveable Pivot (While in a line formation.) [529]

"Right (or Left) – TURN"

All troopers turn to the right (or left). The pivot horse moves slightly forward while turning in a small arc. (This arc is 5 paces long for a 90° turn.) The trooper in the center of the front rank remains at the original speed. The troopers toward the outside of the turn will speed up, and the troopers toward the inside will slow down. All troopers will regulate their speed, according to their position, in order to stay in line.

"FORWARD"

All troopers stop turning and move forward at the original gait.

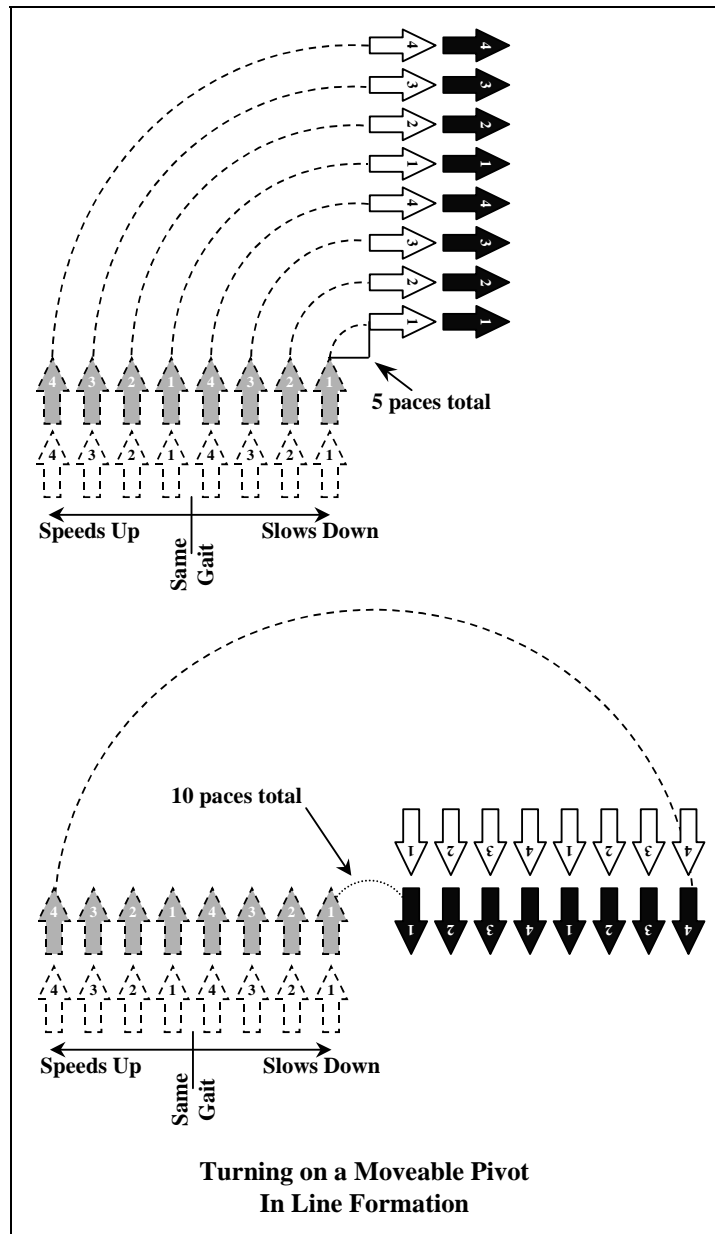

Figure 20

- ☞ Notice the subtle difference in the gaits between a column and a line formation when turning on a moveable pivot.
- While in a column formation, the trooper on the inside of the turn remains at his original speed and all other troopers progressively speed up toward the outside of the turn to stay in line. (See Figure 7.)
 - While in a line formation, the trooper in the center of the line remains at the original speed. The troopers toward the outside of the turn speed up, and the troopers toward the inside slow down. (See Figure 20.)
 - All wheels on a fixed pivot are regulated by trooper on the outside of the turn maintaining the original gait. (See Figures 18 & 19.)

44. Mounted Charge (From a line formation with sabers or pistols drawn.) [418, 569 & 570]

"Platoon (or Company) forward"

"Guide right (or left)"

"MARCH"

The formation moves forward at a walk.

"Trot - MARCH"

The speed is increased to a trot.

"Gallop - MARCH"

The speed is increased to a gallop, maintaining the dress.

"CHARGE"

Speed is increased slightly. Both ranks raise sabers (or pistols). The front rank raises the saber with the tip forward at eye level, the edge of the blade up. The rear rank raises the blade straight up with the right arm half extended, tip slightly to the rear. Keep control of your horse. Take care that the rear rank maintains the proper distance. Poinsett's says "It is better, however, that the rear rank should have too much than too little room." The charge is not an individual race, keep the formation together. The physical shock of the mounted charge is increased by keeping properly aligned and hitting as a tight formation rather than a loose collection of individuals.

☞ The procedures above are straight out of Poinsett's. However, the following modifications should be considered for safety during a mounted charge for a reenactment or living history event:

- Rear rank should either remain at the position of *Carry* – SABER (See paragraph 58) or extent the saber and right arm straight up. (Some events require all riders to maintain the position of *Carry* - SABER at all times while charging.)
- Prior to reaching the enemy's lines, the entire charging formation should slow to a trot, and raise saber points well up.
- Be very careful about charging towards or close to infantry and spectators. Horses can get very excited during a charge and are often difficult to stop.

45. Rallying [571]

"RALLY" (Can also be sounded by bugle)

Each trooper quickly rejoins on the commander, or guidon, by the shortest route. Since a second charge may be ordered before all are back in place - the troopers should swing around the sides and join the formation from the rear so they do not block the front of the formation. Do not try to get back into your original position, just get into a double rank line formation as quickly as possible.

"Six files from the right - as skirmishers"

The commander may use any portion (or all) of the unit as skirmishers. The remaining portion of the unit serves as the reserve to support, or to relieve the skirmishers.

"MARCH"

"Guide right (or left)"

- Reserve: The troopers in the reserve are placed in the command of a junior officer or NCO who commands them to **"Draw - SABERS"** (See paragraph 31).
- Skirmishers: Move forward ten paces then fan out to the left and right. The rear rank moves to the left of their file leaders to form a single line, at least five paces between each man. All skirmishers take the position of *Advance - CARBINE* (See paragraph 53), or *Raise - PISTOL* (See paragraph 55). The commander is half way between the reserve and the skirmishers. The skirmish line continues to advance until the commander (or bugler) calls **"HALT"** with the skirmish line 100 to 150 paces in front of the reserve.

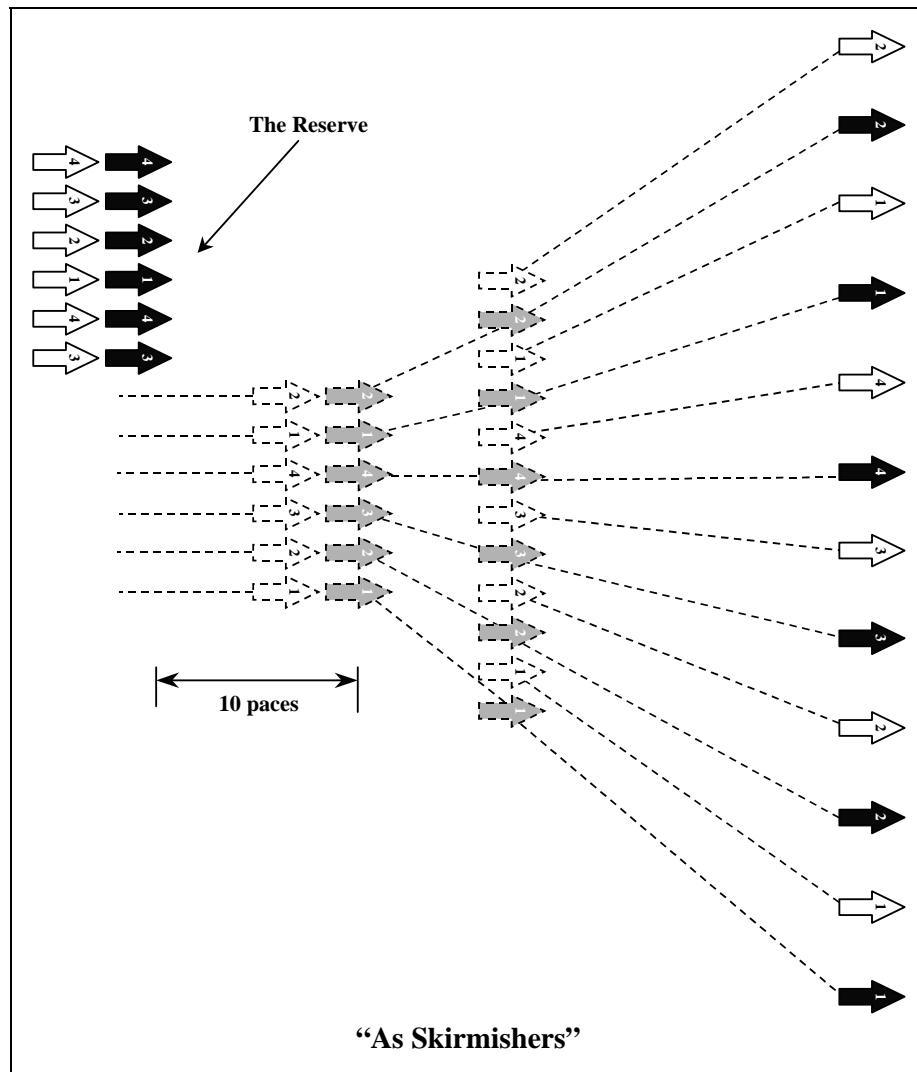

Figure 21

The commander controls the movements of the skirmishers using the commands:

- "FORWARD"
- "HALT"
- "TO THE RIGHT"
- "TO THE LEFT"
- "LEFT ABOUT" (When turning away from the enemy.)
- "RIGHT ABOUT" (When turning towards the enemy.)
- "RETREAT"
- "RALLY"

47. Fighting on Foot [578]

"Prepare to fight - ON FOOT"

Dismount as described in paragraph 4 (page 5), but the number 4s stay mounted and act as horse holders. The number 1s link their horses to the halters of the number 2s, the number 2s link their horses to the halters of the number 3s. The number 3s pass their lead straps to the number 4s.

- Dismounted Troopers: The dismounted troopers hook up the saber, unsling the carbine, and move to form double ranks 12 paces in front of the linked horses, and come to the position of *Carry - ARMS*. (See paragraph 48.) (The commander may fight dismounted in a double rank formation, or he may advance the dismounted men as skirmishers as in paragraph 46.)
- Horse Holders: The commander places a junior officer or NCO in charge of the horse holders, who remain mounted and have control of the linked horses.

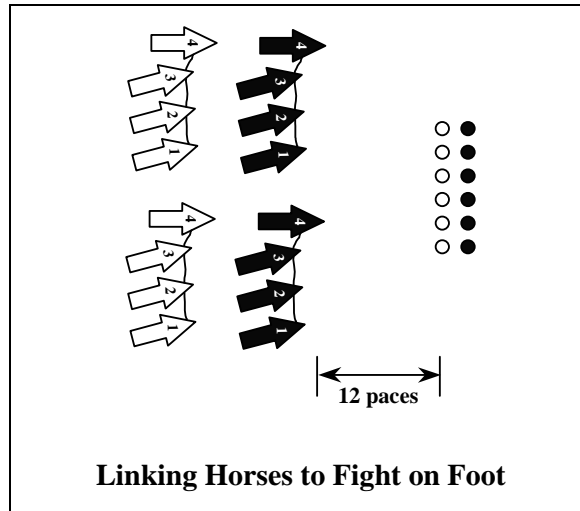

Figure 22

📖 **Linking Horses** 📖

The linking procedures above are slightly different from what is described in Poinsett's. Poinsett's was written before the troopers were issued link straps or lead straps, and the method used called for the troopers to use the reins to tie their mounts to the bridle of the next horse, with the number 4s holding the reins of the number 3 horses. The use of link straps and lead straps during the Civil War was easier, faster, and safer for the horses.

Here are a few more safety tips to follow when linking horses:

- Dismounted troopers should pass the reins over the pommel of their saddle so they do not hang down where the horses could get tangled in them.
- Link straps should be buckled to the halter ring of your own horse, and snapped to the halter square or halter ring, and not the bit, or bridle of the horse you are linking to. This will prevent injuring the horses' mouths if they should pull against the straps.
- If the linked horses do not stand quietly, the horse holders can calm them by slowly walking in a counterclockwise circle. Be careful that you do not get tangled with the other horses.

48. Carry - Arms [36]

"Carry - ARMS"

Stand at attention. Carbine unslung and held in right hand, fingers around the small of the stock. Let right arm hang naturally, holding the carbine with the trigger guard to the front and the barrel straight up and resting against the hollow of right shoulder.

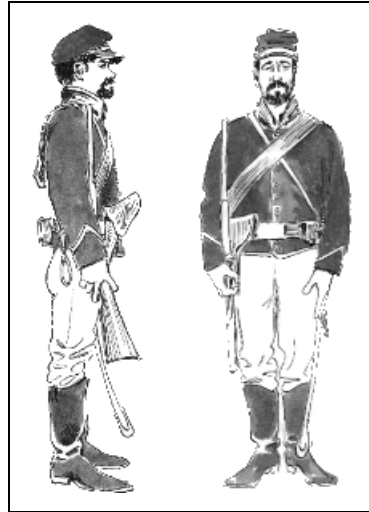

Position of Carry - Arms
Figure 23

49. Order - Arms [41]

"Order - ARMS "

From the position of *Carry - ARMS*, move the carbine slightly forward and grasp it with the left hand near the rear sights. Release right hand and re-grasp the carbine above the left hand. Release left grip and drop left hand to side. Lower carbine and place the butt on the ground next to the right foot. Let right arm hang naturally, holding the barrel between the right thumb and forefinger.

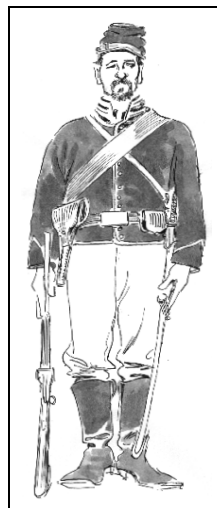

Position of Order - Arms
Figure 24

50. Sling - Carbine [51]

"Sling - CARBINE"

From the position of *Carry - ARMS*, or *Order - ARMS*, raise the carbine in the right hand to about waist level. Grasp carbine with left hand near the rear sights and raise to neck level while turning it so that the trigger guard is facing the rear. Extend left thumb along the barrel to help control the weapon. Tip the barrel to the right at about a 45° angle so that the ring hangs free. Keep left elbow high so that the stock rests against the under side of left forearm. Grasp the swivel snap in right hand and connect it to the carbine ring. Now lower the carbine to right side, letting the muzzle point towards the ground. Push the carbine to the rear and let it hang by the sling. Drop both hands to the sides.

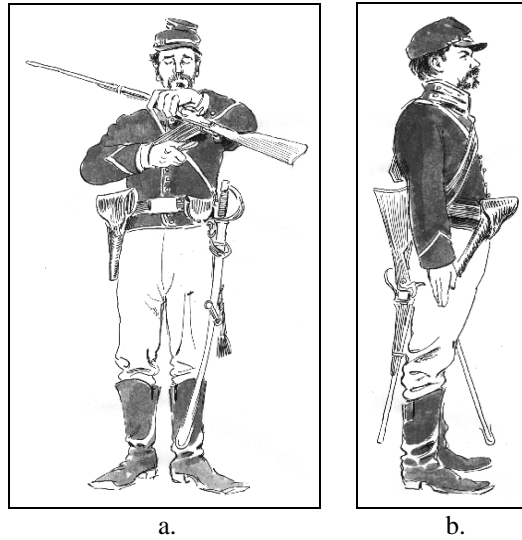

a. b.
Slings the Carbine
Figure 25

51. Unsling - Carbine [52]

"Unsling - CARBINE"

Grasp the carbine at the small of the stock with the right hand and raise it front of the body at neck level with the trigger guard facing the rear. Grasp carbine with left hand near the rear sights and tip the barrel to the right at about a 45° angle. Extend left thumb along the barrel to help control the weapon. Keep left elbow high so that the stock rests against the under side of left forearm. Unhook the swivel snap with right hand and then push the snap to the rear. Now take the carbine high on the barrel with the right hand and take the position of *Order - ARMS*.

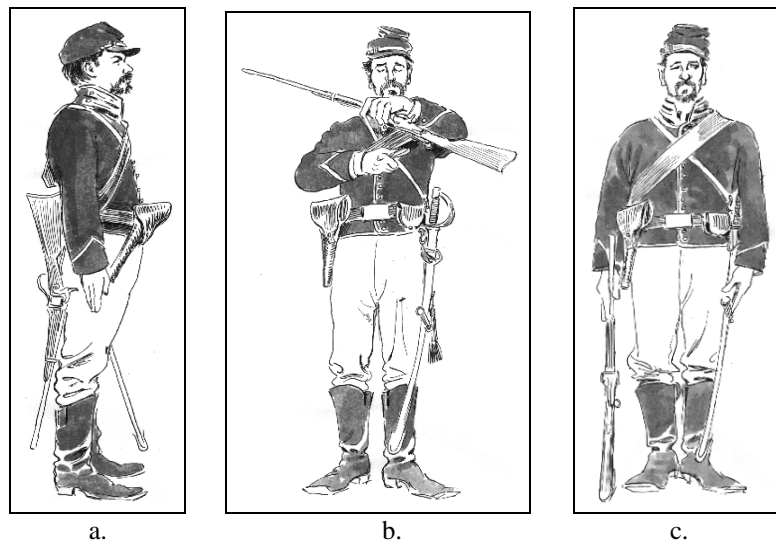

a. b. c.
Unslings the Carbine
Figure 26

52. Inspection - Carbine [97, as for the Hall's carbine]

From the position of *Order* – ARMS, the commander gives the command:

"Inspection - CARBINE"

Raise the carbine with right hand and turn it so the trigger guard is facing towards the left. Grasp the carbine near the rear sights with left hand in front of left shoulder at chin level. Extend left thumb along the barrel to help steady the carbine. Use right hand to ensure the hammer is in the safe (half-cock) position and open the action. Drop your right hand to side. Pause a second, then close the action with the right hand and then execute the movements for *Sling* - CARBINE.

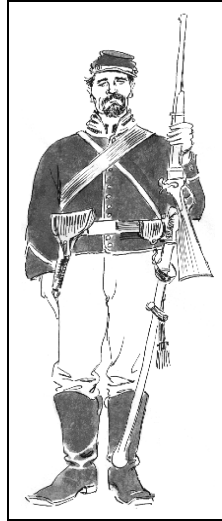

Position of Inspection - Carbine

Figure 27

53. Advance - Carbine (Mounted) [385]

"Advance - CARBINE"

Grasp carbine in right hand and pull the barrel out of the carbine thimble and place the butt of the stock on the right thigh with the muzzle elevated.



Position of Advance - Carbine

Figure 28

54. Drop - Carbine (Mounted) [387]

From the position of *Advance* - CARBINE, the commander gives the command:

"Drop - CARBINE"

Lower the muzzle of the carbine to the right side and place the barrel into the carbine thimble. Allow the carbine to hang from the swivel snap and push the butt of the stock to the rear. (Some folks prefer not to use the carbine thimble for fear of being dragged if they are thrown or fall from their horse.)

☞ Notice that the command *Draw - PISTOL* and *Draw - SABER* both require the trooper to complete a few actions after the preparatory command (*Draw*), but before the command of execution (*PISTOL* or *SABER*). Since the preparatory command is the same for both, this can be confusing. The Officer/NCO in charge should give some kind of a hint to let the troopers know which weapon he wishes by saying something like, "Let's try a pistol charge." or "Here they come with sabers! "

55. Draw - Pistol (Mounted and Dismounted) [Colt Supplement]

"DRAW"

Unfasten the holster flap, and grasp the pistol with the right hand, trigger finger extended along the outside of the trigger guard, then wait for the next command. (You may have to pull the pistol out of the holster a few inches to get a good grip.)

"PISTOL"

Draw the pistol out of the holster and bring it up in front of, and six inches away from the right shoulder, barrel straight up with trigger guard to the front. Keep trigger finger extended along the outside of the trigger guard. This is the position of *Raise - PISTOL*.



Position of Raise - Pistol

Figure 29

☞ **Drawing & Returning the Pistol Safely** ☞

Get in the habit of never pointing the muzzle of your weapons at anyone - **yourself included**. Most troopers end up pointing the muzzle of the pistol at their own sides while drawing/returning the pistol from/to the butt forward holster. Here's a way to draw your pistol (worn on the right side in this example) without ever pointing the muzzle at any part of your own body.

Twist your right hand inwards so that you grasp the pistol grip with your knuckles against the inside of the open holster flap. Now pull the pistol straight up while keeping your knuckles towards your body until you get the barrel all the way out of the holster. Keeping the muzzle pointed at the ground. (This is a little awkward and it helps to keep your elbow high.) Now, still keeping the muzzle pointing at the ground, rotate your hand so that your knuckles are now pointing to the right, then raise the muzzle of the pistol forward. As always, keep your finger out of the trigger guard and away from the trigger. Return the pistol safely by reversing these same steps.

56. Return - Pistol (Mounted and Dismounted) [Colt Supplement]

"Return - PISTOL"

Lower the muzzle of the pistol and return it to the holster and fasten the holster flap. Drop hands to the sides if dismounted. (See Flag Note at the bottom of page 36 for a safety tip.)

📖 **Historically Accurate Pistol Inspection?** 📖

When Poinsett's was first approved in 1841, the cavalry and dragoons were equipped with single-shot, muzzle loading pistols. During inspections, the pistol was placed in the left hand so that the right hand was free to "spring" the ramrods in the barrel. This allowed the inspector to tell from the sound if the weapon was loaded or not. Later, when revolvers were issued, Poinsett's was supplemented with a manual of arms for the Colt revolver. However, these new procedures did not include any changes for inspecting revolvers vice the old muzzle loading pistols. This leaves us modern reenactors with a slight dilemma: Poinsett's pistol inspection does not lend itself well to revolvers (there appears little reason to pass the revolver to the left hand since there is no ramrod to draw), yet the new Colt supplement offers no new procedure.

The next version of Cavalry Tactics ("Cooke's Tactics" - originally approved in 1861) rewrote the pistol inspection such that the pistol was held in the right hand, in front of the chest with the butt at belt level. (This is a little scary because this leaves the muzzle of a potentially loaded weapon pointing near the faces of both the trooper and the inspector.)

With all of this in mind, the directions for pistol inspection below were written by the author with a little bit of literary license. The movements closely follow the feel of Poinsett's, but borrow from the procedures written by General Cooke for use with the revolver. As stated in the introduction of this manual, if anyone has another interpretation, or historical documentation on this, or any other issue, please bring it to the author's attention.

57. Inspection - Pistol [403]

"Inspection - PISTOL"

Draw pistol as described in paragraph 55, but without pausing between the steps. Place pistol in the left hand, barrel tipped slightly to the left. Place the hammer in the safe (half-cock) position with right hand, then drop the right hand to the side. Hold pistol in left hand, in front of left shoulder, trigger guard to the left, left forefinger extended outside the trigger guard. Pause a second, then reach back up and lower the hammer (between two cylinders) with right hand. Now take the pistol in right hand and return to the position of *Raise - PISTOL*. Pause one more time, then return pistol as in paragraph 56.

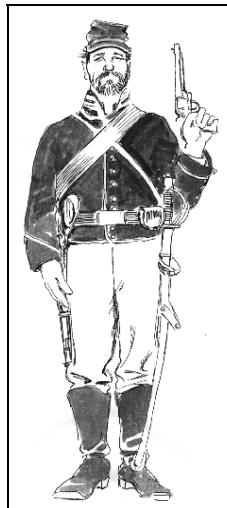

Position of Inspection - Pistol
Figure 30

58. Draw - Saber (Mounted and Dismounted) [93 & 378]

"DRAW"

Turn head to the left and look down at the saber. Grasp the scabbard in the left hand at the upper ring, unhook the scabbard from the belt and bring the hilt to the front. Place right hand through the saber knot and draw the blade six inches out of the scabbard. Face back to the front and wait for the next command. (See Figure 31a.)

"SABER"

Draw the saber the rest of the way out of the scabbard and fully extend the right arm, holding the saber up at a 45° angle in front of the right shoulder. Pause a second, then lower the right hand to the right hip, letting the back of the blade rest against the hollow of the right shoulder, edge to the front. Hold scabbard against left leg with the left hand. This is the position of *Carry - SABER*. (See Figure 31b.)

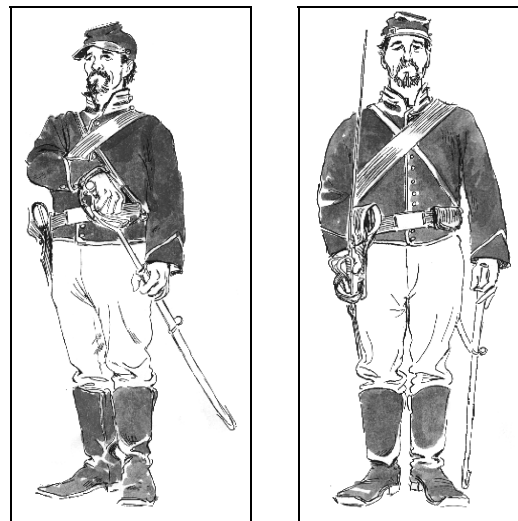

a.

b.

Drawing the Saber

Figure 31

59. Present - Saber (Mounted and Dismounted) [94 & 379]

From the position of *Carry - SABER*, the commander gives the command:

"Present - SABER"

Bring the saber up in front of the face with the edge to the left, blade straight up, right hand even with and six inches in front of the neck. Extend right thumb along the back of the grip to steady the saber.

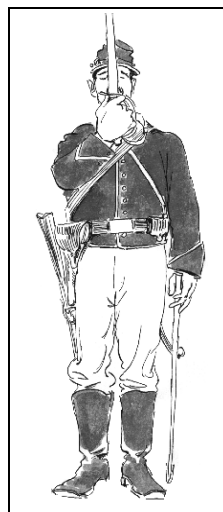

Position of Present - Saber

Figure 32

60. Carry - Saber (Mounted and Dismounted) [95 & 380]

"Carry - SABER"

If dismounted:

Lower the right hand to the right hip, letting the back of the blade rest against the hollow of the right shoulder, edge to the front.

If mounted:

Lower the right hand and place the grip on the upper part of the right thigh, letting the back of the blade rest against the hollow of the right shoulder, edge to the front.

61. Return - Saber (Mounted and Dismounted) [96 & 381]

From the position of *Carry - SABER*, the commander gives the command:

"RETURN"

Execute *Present – SABER* (paragraph 59) and wait for the next command.

"SABER"

If dismounted:

Move the right hand over in front of and six inches from the left shoulder. Lower the blade until it touches the left arm, keeping the point to the rear. Turn the head and look down at the scabbard. Continue lowering the tip, rubbing the blade against your left arm to steady it and place the saber in the scabbard. Remove right hand from saber knot and rotate scabbard inwards one half turn and hook the top ring on the belt hook with the hilt to the rear. Drop both hands to the side and face back to the front.

If mounted:

The same movements as for dismounted except that the left hand is holding the reins, and the Scabbard is not hooked up when mounted.

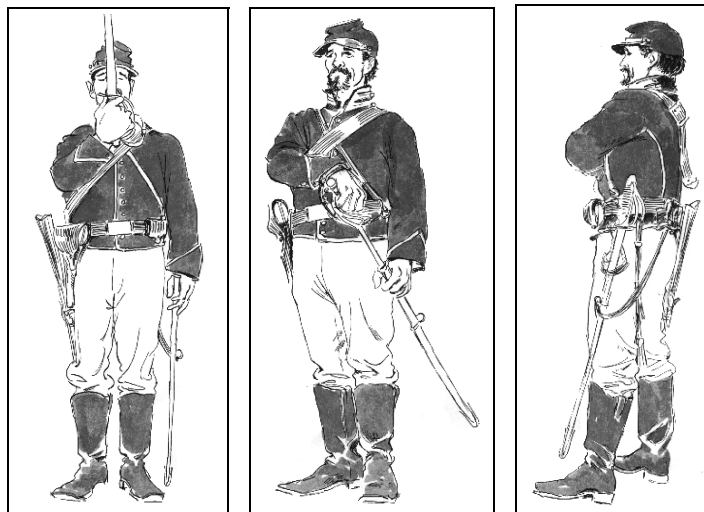

a..

b.

c.

Returning the Saber

Figure 33

☞ Returning the saber when mounted can be a challenge (especially while moving) because your left hand is holding the reins and you will not be able to use it to steady the scabbard. The secret is to rest the blade on your left forearm to steady it. You can then move your left elbow around to help you guide the blade into the scabbard.

62. Inspection - Saber [98]

"Inspection - SABER"

Draw the saber as described in paragraph 58, but without pausing between the steps. Pause a second at the position of *Carry - SABER*, then execute *Present - SABER* (paragraph 59). Pause another second then rotate the right wrist inwards to show the over side of the blade, pause again, then turn the saber back so the edge is again to the left. Pause, then return to the position of *Carry - SABER*, pause one last time, then return the saber as in paragraph 61 on page 39.

🔗 **Formal Weapons Inspection** 🔗

Almost all reenactments require a weapons inspection to ensure the proper operation and safety of each weapon used at that event. This requires the inspector to look into the barrel and chambers of each weapon to ensure that there are no obstructions that could become a projectile when the weapon is fired. Therefore — **All firearms must be kept unloaded until after the inspection.**

Poinsett's outlines the inspection of each weapon with separate commands for each (*Inspection - CARBINE*, *Inspection - PISTOL*, and *Inspection - SABER*) with the men all presenting their weapons for inspection simultaneously, pausing a second, and then slinging or returning their weapons. Of course this does not allow a close inspection of the individual weapons, and is only for the purpose of instructing, or drilling the men in the proper movements.

For a detailed, "hands-on" inspection of each trooper's individual weapon, the Officer/NCO in charge gives the command "*Inspection - ARMS.*" The execution of this command requires putting together many of the motions described above. Each of these motions are executed in turn, but "*Inspection - ARMS*" the only command given.

Paragraph 63, on page 41, is a chronological outline of the required movements for the inspection of all three weapons.

63. Inspection of Arms [5, 92, 99 & 405]

The Officer/NCO in charge will get everyone together with a command such as:

"FALL IN FOR WEAPONS INSPECTION"

The troopers fall in dismounted, in double ranks at open order (six feet between ranks). The saber is hooked up on the belt, hilt to the rear. Carbine is unslung and held at the position of *Carry* - ARMS. When everyone is in place, the Officer/NCO in charge commands:

"Attention - COMPANY (or Platoon/Squad)"

All troopers stand at attention and remain silent.

"Right - DRESS"

"FRONT"

See paragraph 6.

To keep the troopers from becoming fatigued while they are waiting to be inspected, the Officer/NCO in charge commands:

"Order - ARMS"

All troopers simultaneously execute *Order* - ARMS. (If the ground is wet or muddy, the Officer/NCO in charge may choose to conduct the inspection with the troopers at the position of *Carry* - ARMS.)

"Inspection - ARMS"

Carbine Inspection

All troopers remain at the position of *Order* - ARMS (or *Carry* - ARMS). Each trooper individually executes the first part of *Inspection - Carbine* when the inspector steps in front of him. When the inspector takes the carbine, the trooper drops left hand to side. (Do not extend left arm to hand the inspector the carbine - let him take it from you.) Trooper remains at attention while the inspector checks weapon for proper operation, safety, and cleanliness. When done, the inspector will close the action, lower the hammer, and hand the carbine back so that the trooper can again take it in his left hand and hold it at chin level as before.

Once the inspector moves two men down, the trooper then executes:

Sling - CARBINE

Draw - PISTOL

First part of *Inspection* - PISTOL

Pistol Inspection

Each trooper remains at the position of *Inspection* - PISTOL until the inspector returns. When the inspector takes the pistol, trooper drops left hand to side and remains at attention. (Again, do not extend left arm to hand the inspector the pistol - let him take it from you.) When done, the inspector will drop the hammer between two cylinders and hand the pistol back so the trooper can again take it in his left hand and hold it at shoulder level as before.

Once the inspector moves two men down, the trooper then executes:

Return - PISTOL

Draw - SABER (but without using the saber knot.)

Saber Inspection

Each trooper remains at the position of *Carry* - SABER until the inspector returns for the final inspection. Each trooper individually executes *Present* - SABER when the inspector steps in front of him. Watch the inspector's eyes - when he is done looking at the right side of the blade rotate the saber to allow him to see the other side. Again, watch the inspector's eyes - when he is done looking at the other side of the blade turn the saber back to the original position of *Present* - SABER. The inspector will then take the saber from the trooper to check the security of the blade and the grip. When done, the inspector hands the saber back to the trooper to hold at the position of *Present* - SABER.

Once the inspector moves two men down, the trooper then executes:

Carry - SABER, pauses a second then

Return - SABER, re-hooks the scabbard, and remains at attention.

